

A Material Revolution

Abstract

No text on materials would be complete without a discussion about the techno-process whereby the planet supplies resources, we use them and then throw what is left away. Materials are virtually everything between the take and waste in this process and it follows that for sustainability what they are made of and how they are made is very important.

The idea that we can save the planet from a slow techno induced death, solve global warming, waste and a number of other environmental problems by making money doing so sounds preposterous but is however uniquely likely to succeed.

An economically driven energy and materials revolution requiring paradigm shifts in the technology underlying materials and thus the underlying molecular flows around the planet is essential if the many problems we face including use impact, waste and carbon dioxide in the atmosphere are going to be solved.

How this revolution will occur and new materials for the built environment being delivered by it are described.

Keywords

Biosphere, geosphere, industrial ecology, economics, supply, demand, value, impact, utility, economies of scale, legislation, sequestration, abatement, sustainable, sustainability, carbon dioxide (CO₂), concrete, process energy, embodied energy, lifetime energy, eco-cement, tec-cement, enviro-cement, kiln, tec-kiln, calcine, grind, geopolymers, brucite (Mg(OH)₂), reactive, magnesium oxide (MgO), nesquehonite (MgCO₃·3H₂O), lansfordite (MgCO₃·5H₂O), magnesian, magnesia (MgO), magnesium carbonate, magnesite (MgCO₃), fly ash, pozzolan, hydraulic cement, Portland cement.

The Author - John Harrison

John Harrison has degrees in science and economics, is the managing director and chairman of TecEco Pty. Ltd. and is known around the world for the invention of tec, eco and enviro-cements. He is an authority on sustainable materials for the built environment, has been the keynote speaker at many conferences and is committed to finding ways of “materially” improving the sustainability of the built environment.

Overview

For the last several billion years nature has nurtured the planet evolving complex eco-systems (the biosphere) that conserve and recycle energy and materials.

Much is to be learned from the study of mature climax eco-systems which demonstrate complex web-like integration, conserving energy all of which is ultimately derived from the sun as it flows through the system and materials which are constantly recycled, the waste from one natural metabolism being the input of another.

Plants and animals live together in mutually interdependent ways that become increasingly specialized developing mechanisms for regulation preventing overgrowth or dominance. The wonder of nature is the complexity of this interdependence and how extremely efficient it is at recycling the nutrients essential to life.

Occasional aberrations are triggered climatically, by fire, cataclysmic events or some other way. Species are wiped out (as were the dinosaurs) and new species or groups of species appear to take over. In the past however the biosphere has always come back into to a balance characterized by complexity and integration but this can take thousands and sometimes millions of years.

Along came humans. In the last hundred years or so and for the first time in geological history we have become masters of the destiny of the rather unique blue green planet we live on.

We are like no other cataclysmic event yet we are responsible for many of the changes affecting the geosphere-biosphere from salinity, de-forestation and pollution to the global carbon dioxide balance.

Climate change is the most visible result - storms, droughts, floods and the like are rising in frequency and severity and the consensus is that we are to blame.

In nature climax communities are stable. Our presence on the planet is non-climax, non stable and non sustainable. Driven by our intelligence, greed and arguably, cheap fossil fuel energy and like a new predator before which no living thing can stand we are taking over. We are however the agents of our own eventual doom. We are choking and poisoning ourselves - slowly. It's a bit like the old agar dish experiment from biology at school - remember how it works? You put a spec of bacteria in the middle of a food supply loaded in agar jelly and behold - the bacteria grows in a ring to the edge of the dish dying in the middle as the poisons it has released in its world (the dish) kill it. There is no escape. We are so ignorant that few understand the flows checks and balances vital to the maintenance of the biosphere as a whole. There will be a natural correction. Will it involve our own extinction? Should we wait to find out?

First the village smithy, then James Watt and the steam engine followed by oil, abundant energy and thousands if not millions of innovations later and we have a tiger by the tail called the techno-process. It is bigger than we are, more ubiquitous, far reaching and in its name some five or six hundred billion tonnes of matter is moved about the planet to create the twenty or thirty billion tonnes of new materials we actually use every year.

The tremendous appetite of the techno-process is irreversibly changing the planet. The earth that nurtures us has limits that we have now most certainly exceeded.

Resources are supplied by the geosphere-biosphere one way or another and are not infinite. Needs change and the things we make out of materials wear out. Eventually everything is thrown away. All this activity has an impact on the planet and it seems vital earth systems are unable to cope and are rapidly going out of balance. It appears impossible for humans to correct the problem on such a large scale.

What options does that leave us? Kyoto is a symbolic start but that is all. What does nature teach us?

Economics could perhaps be defined as the set of common behaviors that string together our interactions for survival. It is about the application of resources to needs. Economics drives both the techno-process and nature – both are based on survival but there are some fundamental differences between our techno-process and natural systems. Nature uniquely embraces integration and balance, seen as desirable by economists but unfortunately missing from the techno-process. Economists should study ecology for a few clues about where we are going wrong.

The cataclysmic event in our evolution has been the development of machines energized by fossil fuels. The resulting techno-process is simple, linear, non-integrated and arguably non-climax. Linear systems cannot be balanced because they cannot possibly contribute as much as they take. Climax eco-systems in the biosphere are on the other hand are characterized by complex integration and balance.

Efficiency is important for profit which drives the allocation of resources. Unfortunately we only seem to understand efficiency in a linear sense, not an integrated one. The greatest proponent of efficiency, Henry Ford developed a linear production line to which resources were delivered. There was no concern for resource issues beyond the factory gate – that was somebody else's problem or nature would provide. Enterprise based efficiency espoused by Henry Ford neglects the value of the natural capital or the planet as a whole.

Climax ecologies are characterized by extremely efficient systems in which all processes are integrated. For example a leaf is technically designed to minimize water loss and maximize photosynthetic production. When the leaf falls to the ground it is eaten by bugs, grubs and bacteria and eventually it

provides nutrients for the trees above it in what is a highly efficient process that retains embodied energy from the sun and recycles materials indefinitely.

Liquid and gaseous fossil fuels are now running out and the techno-process cannot continue the way it has in the past. The planet is in crisis. It is time for change so the total net consumption of energy and materials is much less. Can the intelligence of the computer chip provide the connections to close the loops in our linear techno-process, can we invent new materials that do not have such an impact on the planet. Can we live in harmony with the planet? These are the big questions.

The only driving force humans answer to on a large scale is economics, but like a mirror, economics is really only a measurable reflection of how we really are, how we think and act. Economics is the driver of the techno-process. Technology however defines what moves through it and how. In this simple understanding lies the clue. Maybe we can redefine materials so economics drives more sustainable processes? Can we re-invent our physical world? In my view we are going to have to if we want to survive.

Natural climax eco-systems involve conservation of energy and materials, integration and thus recycling and provide the example as to how this could be done. How can we mimic nature and yet still obey the rules of economics?

Can we harness economic forces to bring about change in what is a linear, substantially un-integrated techno-process¹ and develop a more sustainable regional industrial ecology which conserves materials and energy in the system as a whole, to a desirable extent complements nature and that is highly integrated with much more recycling and re-use.

Technology, which primitively used created the industrial revolution and the linear techno-process can be turned to the greater cause of producing an industrial ecology which is integrated and efficient and which has minimal impact on the planet. The need is obvious. Technology is the means. Linked with the will we may yet reduce our footprint on the planet until it is hardly noticeable. As part of this a paradigm shift in the technology underlying materials is required.

The opportunity for change is greatest in the built environment which after all encompasses the greatest materials flows on the planet with the largest take and waste impacts. Taking into account infrastructure governments are uniquely the largest constructors on the planet and have the opportunity, if not the responsibility to encourage and implement new technologies that will make the difference.

Architects engineers and specifiers are uniquely positioned to take advantage of the changes that are occurring and drag the rest of the supply chain into delivering sustainability.

¹ Take, manipulate use and waste.

Major Themes

1. Sustainability is a goal not a benchmark.
2. There is a techno-process describing our activities on the planet of taking resources, manipulating molecules, making new “things”, using these “things” and eventually throwing them “away”.
A special case of the techno-process is the extraction and burning of fossil fuels.
3. Materials are everything between the take and waste
4. By re-engineering materials we can reduce the volume and impact of the take and waste.
5. The built environment offers enormous opportunities for re-engineering materials and improving sustainability.
6. The only way to make any of the above happen on a global scales is economically

Theme Statement

The technology paradigm defines what is or is not a resource in an economic system that drives materials flows through the techno-process. By harnessing basic human psychology through cultural change to achieve greater demand for sustainable outcomes delivered by evolving and changing techno-processes that sustainably deliver cost effective solutions economics will define more sustainable resource flows.

A Planet in Crisis?

Global population, consumption per capita and our footprint on the planet is exploding. The impacts are affecting every indicator of the health of the planet.

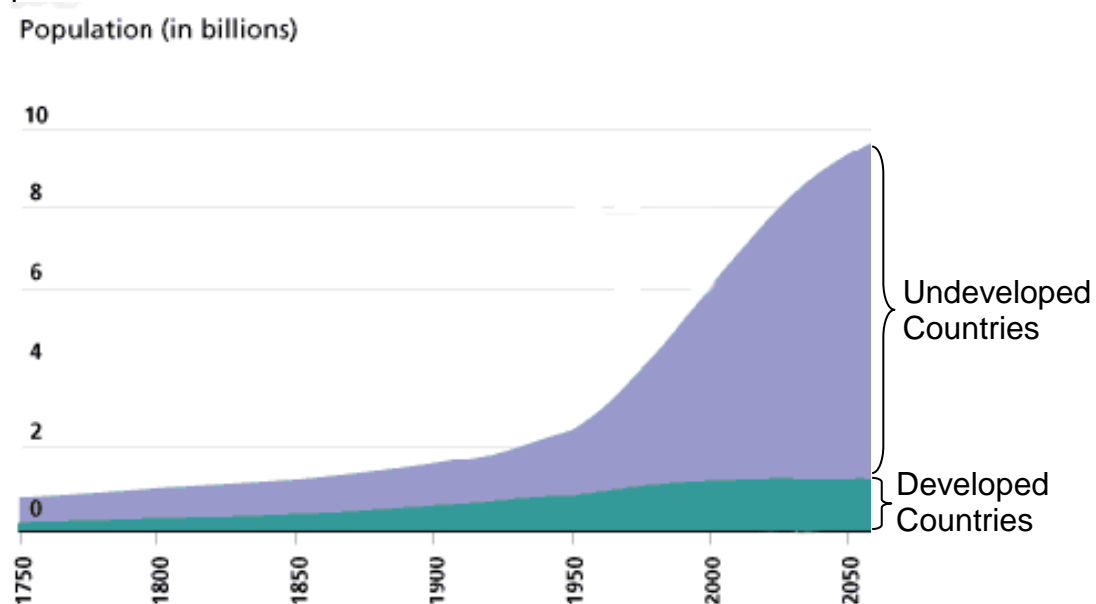

Figure 1 - World Population Growth 1750-2050. Population in billions (after UN, 2002)

The world population passed 6 billion in 1999 and at the current rate of growth the world will have 7 billion people soon after the year 2010. The overwhelming share of world population growth is taking place in developing countries (95.2% in 1990-2000, an estimated 97.6% in 2000-10 and 98.4% in 2010-20) where the population has more than doubled in 35 years, growing from 1.89 billion in 1955 to 4.13 billion in 1990 (UNCHS, 2004)

“Significant proportions of population increases in the developing countries have been and will be absorbed by urban areas (71.8% in 1990-2000, an estimated 83.4% in 2000-10 and 93.4 in 2010-20). Urban settlements in the developing countries are, at present, growing five times as fast as those in the developed countries. Cities in the developing countries are already faced by enormous backlogs in shelter, infrastructure and services and confronted with increasingly overcrowded transportation systems, insufficient water supply, deteriorating sanitation and environmental pollution.” (UNCHS, 2004)

The World Resource Institute recently published a document titled “The Weight of Nations” which demonstrates that over the last fifteen years per capita consumption of resources to produce materials and the per capita production of wastes are increasing in spite of increasing efficiencies and a slight de-coupling of GDP per capita from energy use per capita and material use per capita.

It follows that gross consumption and gross waste production are also increasing (WRI, 2004).

In October 2004, the World Wildlife Fund released The Living Planet Report 2004 which confirms that ecological overshoot has become a reality: humanity is now consuming over 20 percent more natural resources than the Earth can produce (WWF, 2004).

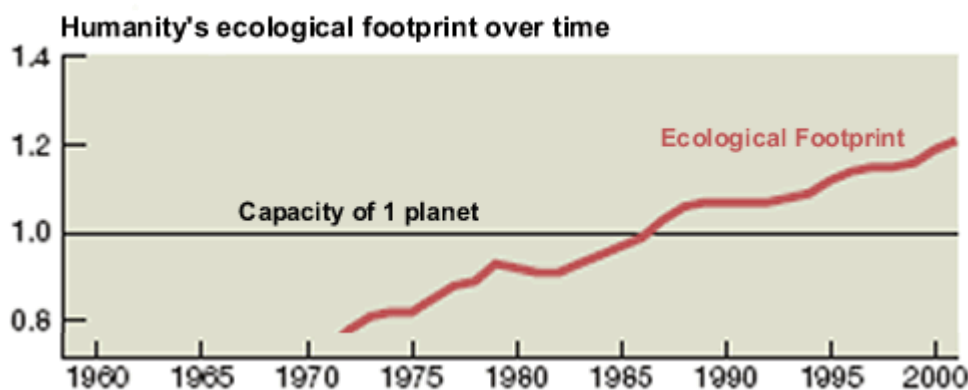

Figure 2 - The WWF's World Ecological Footprint Index (WWF, 2004)

The WWF report exemplifies the relevance of the ecological footprint tool for decision-makers and defines humanity's challenge for the 21st century as learning to live within the means of our planet. According to the report “deficit spending’ leads to the destruction of ecological assets, on which our economy depends, such as depleted groundwater, collapsing fisheries, CO₂ accumulation in the atmosphere, and deforestation. Human beings already use over half the world’s accessible surface freshwater, have transformed

one-third to one-half of its land surface, fix more nitrogen than do all natural systems on land, and appropriate more than two-fifths of the planet's entire land-based primary biological productivity" (Vitousek, P. M., Mooney, H. A. et al., 1997). The doubling of these burdens with rising population will displace many of the millions of other species, undermining the very web of life."(Hawken, P., Lovins, A. et al., 2000)

World systems are interconnected and under stress. Daily we hear about salinity, water, weather, fishery, waste, global warming and other issues. Most news about the health of the planet is unfortunately bad. Much of it is documented in a recent report on the International Geosphere-Biosphere web site (Steffen, W. and Tyson, P., 2001) ².

Of particular concern and therefore the most studied is the problem of CO₂ in the atmosphere. The level of CO₂ in the air from the burning of fossil fuels is rising too rapidly for natural processes to absorb and has risen from 280 parts per million in pre-industrial times to around 380 parts per million in 2004. Between 2001 and 2002 the rise was from 371.02 to 373.10 parts per million, an increase of 2.08 over the year. Then it rose again in 2003 to 375.64 parts per million, an annual increase of 2.54 – the first time the rise was over two parts per million in two years.

Just as concerning is the fact that methane concentrations have also risen by 145 percent over the same period and oxygen levels have fallen. Before the industrial revolution gaseous chlorines did not exist in the atmosphere. By 1996 there were 2 731 parts per trillion, most of these produced in the 20th century (WRI, 1998).

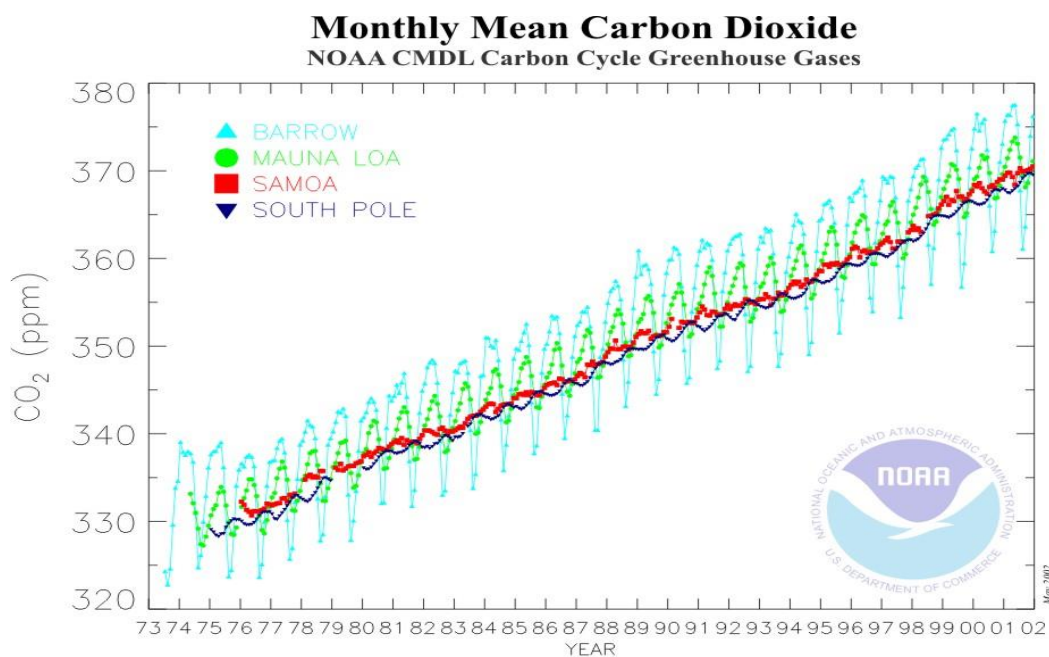

Atmospheric carbon dioxide mixing ratios determined from the continuous monitoring programs at the 4 NOAA CMDL baseline observatories. Principal investigator: Dr. Pieter Tans, NOAA CMDL Carbon Cycle Greenhouse Gases, Boulder, Colorado, (303) 497-6678 (ptans@cmdl.noaa.gov, <http://www.cmdl.noaa.gov/ccgg>).

Figure 3 - Global CO₂ Balance (CMDL, 2003)

² IGBP SCIENCE No. 4 downloadable from the International Geosphere – Biosphere web site

The well documented result of the increase in CO₂ in the atmosphere has been global warming and climate change accompanied by devastating sea level rises.

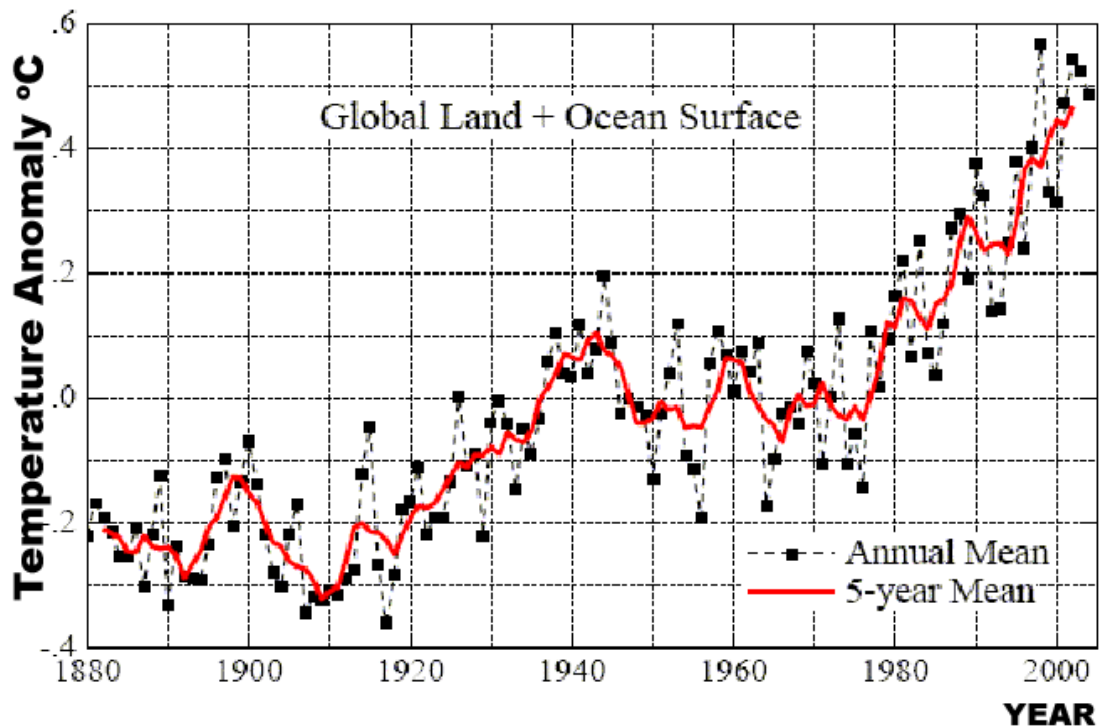

Figure 4 - Global Temperature Anomaly (GISS, 2005)

We move around some 500 (Hawken, P., Lovins, A. et al., 2000) or 600 million tones of material every year and use a trifling 50 billion tones³. Most of the rest is waste. Even that which is used is eventually wasted. Fortunately much of this waste is biodegradable however there are still several hundred kilos of non-biodegradable waste per person on the planet to safely dispose of. The production and disposal of waste is also a major global issue.

Simply put, there is ample evidence that increases in consumption per person and population growth have compounded to unsustainable levels.

Sustainability

Definitions as to what the words sustainable, sustainability and so on mean abound.

The concept of sustainability was brought to prominence by the then Prime Minister of Norway, Mrs Gro Harlem Brundtland in the World Commission for Sustainable Development which defined sustainable development is “development that meets the needs of the present without compromising the ability of future generations to meet their own needs”(Brundtland, G. H., 1987).

“Living within the means of the planet”

³ My own very rough estimate.

“Value for impact”

“the concept of striving for sustainable development is not so much a ‘destination’ at the end of a road but like life, more a ‘manner of travelling’ (CICA, 2002)”.

We can say however we are succeeding when our footprint is reduced, when trends are reversed such as the level of CO₂ in the atmosphere and when water quality, sanitation and other benchmark measures improve.

Sustainable materials and processes are all relative. Something that is sustainable in one context may not be in another; what is sustainable today may not be tomorrow and so on. We can however always compare our efforts towards sustainability to nature. Natural processes⁴ are usually as a whole balanced, integrated and efficient.

Some aspects of sustainability are easier to understand than others. One thing is clear however. To live more sustainably we must reduce the impact of our activities on the earth’s systems by what I call the techno-process described on page 15.

The Earths Systems

The planet has well-connected natural systems. Carbon dioxide emitted in one country is rapidly mixed throughout the atmosphere; pollutants released into the ocean in one location are transported all over. Local and regional emissions create global environmental problems. There is in effect a “global commons.”

Earth system science involves:

1. Exploring interactions among the major components of the earth system.

These are:

- The biosphere - Living organisms and the part of the earth and its atmosphere in which living organisms exist or that is capable of supporting life.
- The atmosphere - earth's vital blanket of gases
- The geosphere - The solid earth including the continental and oceanic crust as well as the various layers of the Earth's interior.
- The hydro-sphere - earth's circulating water systems
- The energy system - the energy that powers all Earth's systems

2. Distinguishing natural from human-induced causes of change, and

3. Understanding and predicting the consequences of change.

⁴ See www.biomimicry.org

As we learn about how the earth works from our study of biology, geology, hydrology, metrology and so on we have recognised patterns that help us understand how our planet works. Some of the most important patterns are:

- Networks - how life and planetary systems are connected to each other
- Cycles - how matter gets used over and over again
- Flows - how matter and energy move from place to place
- Balance - how change is regulated.

It is difficult to completely understand let alone quantify the complex flows and balances that go on around the planet. We do know however that pollution from wastes of various kinds has affected atmospheric composition, land cover, marine ecosystems, coastal zones, freshwater systems, global biological diversity and many other global systems.

Due to our pervading interference the constituent components of matter which are molecules are no longer produced or used in equilibrium. Complex carbon based molecules put together by living matter over many millions of years are being used as if there was no tomorrow.

Carbon and Oxygen Flows

Rising atmospheric carbon dioxide concentration and its potential impact on future climate is an issue of enormous global significance. Also of concern is the depletion of oxygen in the atmosphere.

Both carbon and oxygen are present in a combined form as CO_2 because of their importance in reduction and oxidation processes. Carbon dioxide is currently around 380 ppm whilst oxygen as O_2 is just over 20 %. Nitrogen as N_2 is ubiquitous at around 78%.

The Carbon Cycle

Even though oxygen in the atmosphere is declining there is a lot more of it than carbon so of greatest concern at the present time is the balance of the carbon cycle which is a complex series of processes through which many of the carbon atoms in existence rotate.

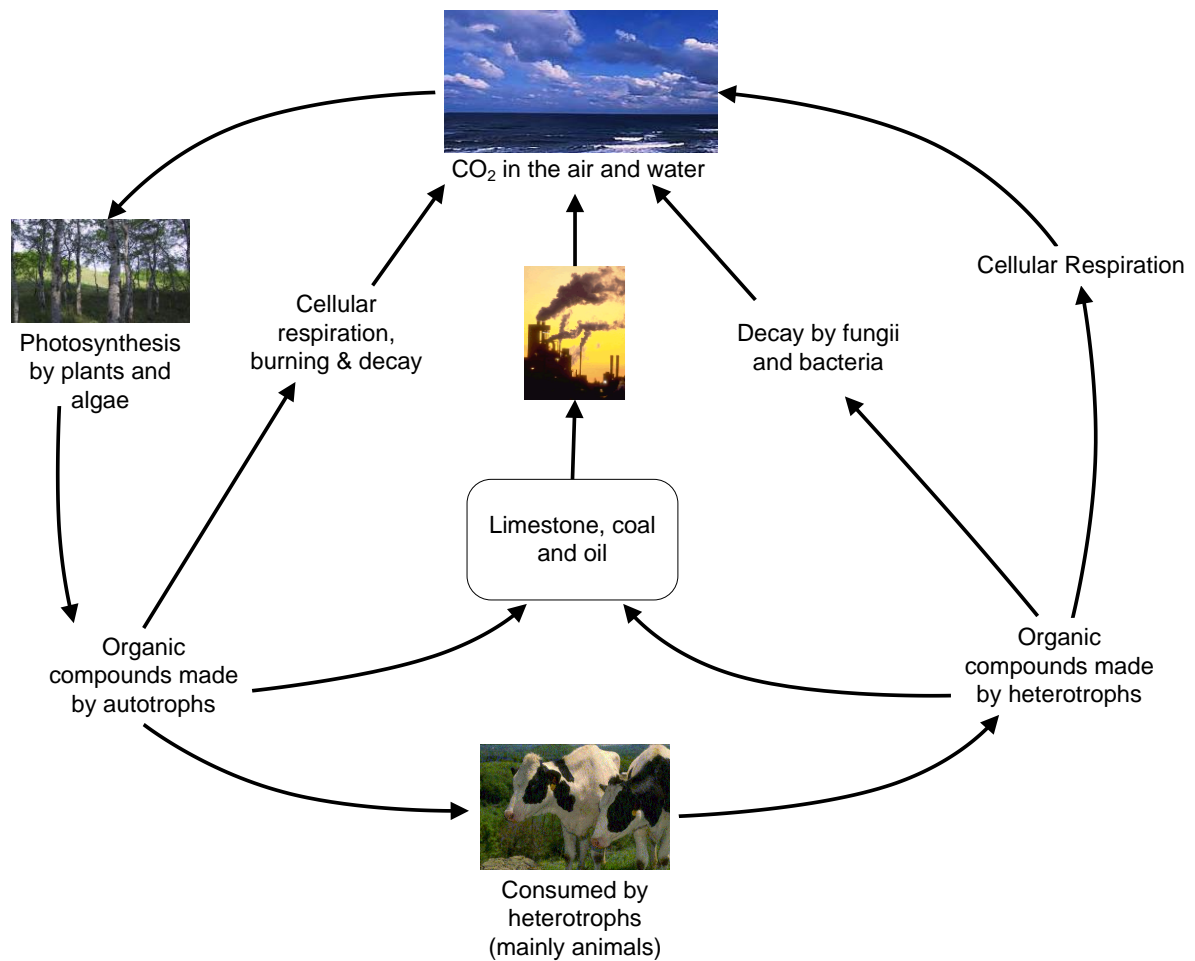

Figure 5 - The Carbon Cycle (Adapted from Kimball (Kimball, J. W., 2004)).

Carbon is a major courier of energy. Plants capture energy from the sun using the DNA driven photosynthesis process as a result of which carbon is fixed in their structures. Animals consume food produced in this way releasing the stored up energy and CO₂. We also burn what was once living to obtain energy and release CO₂.

Living plants and the geological remains of living plants and animals are major reservoirs of carbon. While there is considerable debate about the magnitude and location of these sinks, there is strong evidence that they are very significant.

The carbon cycle is out of balance and as concentrations in the atmosphere increase the earth is undergoing “global warming” and climatic disruption.

Agriculture and many cities are threatened by climate change and a predicted rise in sea level. Unless reversed climate change will, in time, impact severely on the world as we know it. We have the power to reverse climate change. Do we have the sense?

Large quantities of carbon dioxide are released by burning fossil fuels – according to the Wood’s Hole Institute (Haughton, R., 2004) “The

concentration of CO₂ in the atmosphere has already increased by about 30% since the start of the industrial revolution sometime around the middle of the 19th century and will continue to increase unless societies choose to change their ways.” We are also destroying the living carbon sink by manipulating land surfaces for water management, settlement, food and energy production.

As Figure 4 - Global Temperature Anomaly (GISS, 2005) on page 8 shows, there has been a strong warming trend over the past 30 years, a trend that has been shown to be due primarily to increasing greenhouse gases in the atmosphere. El Niños, in which warm water spreads over the tropical Pacific Ocean, are one major cause of fluctuations about the long-term trend. There was a very strong El Niño in 1998, while a weak El Niño existed for the last several months of 2002. The fact that 2002 is almost as warm as the unusual warmth of 1998 is confirmation that the underlying global warming trend is continuing (GISS, 2002)

According to the Wood’s Hole Institute (Haughton, R., 2004) “Most of the increase in atmospheric CO₂ concentrations came from and will continue to come from the use of fossil fuels (coal, oil, and natural gas) for energy, but about 25% of the increase over the last 150 years came from changes in land use, for example, the clearing of forests and the cultivation of soils for food production.”

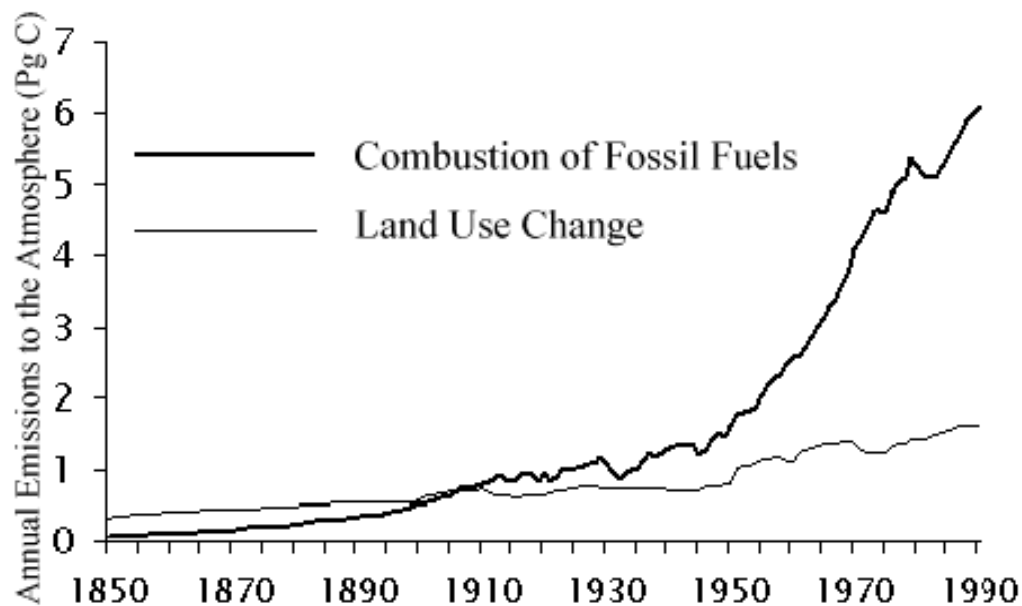

Figure 6 -The Clearing of Forests and the Cultivation of Soils for Food Production after Haughton (Haughton, R., 2004)

Numbers in the Carbon Cycle

Summary totals presented by the Wood’s Hole Institute (Haughton, R., 2004) for carbon in the carbon cycle during the decade ending 2000 (in billion metric tonnes or petagrams) are:

Atmospheric = Emissions + Net emissions - Oceanic - Missing

increase	from Fossil fuels	from changes in land use	uptake	carbon sink
3.2(±0.2)	= 6.3(±0.4)	+ 2.2(±0.8)	- 2.4(±0.7)	- 2.9(±1.2)

Converting⁵ to tonnes CO₂ this is:

$$\text{Atmospheric increase} = \text{Emissions from Fossil fuels} + \text{Net emissions from changes in land use} - \text{Oceanic uptake} - \text{Missing carbon sink}$$

$$11.73 (\pm 0.73) = 23.086 (\pm 0.147) + 8.062 (\pm 2.93) - 8.795 (\pm 2.57) - 10.627 (\pm 4.40)$$

In general agreement with other research there appears to be a discrepancy which is believed to be because there has been a greater than measurable amounts taken up by living plant sinks and possibly the ocean. We may also be increasing the overall size of our atmosphere.

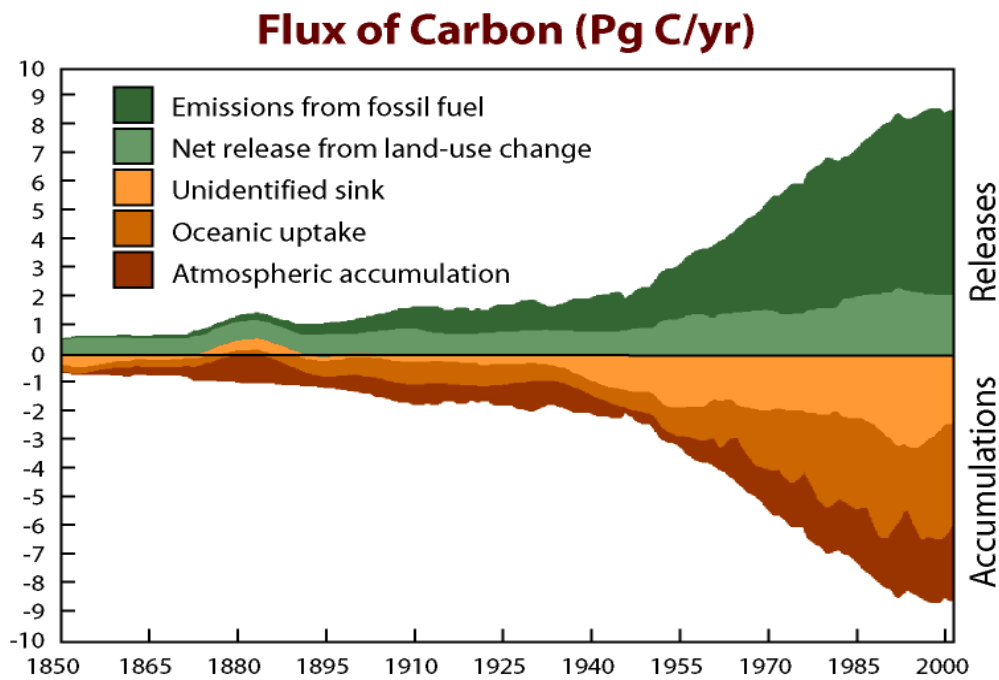

Figure 7 - Sequestration and Emission of Carbon Dioxide (Haughton, R., 2004).

A description of all the other earth systems including for example the hydrosphere; of which freshwater systems are a part and in relation to which water quality, salinity and supply are major issues or sea fisheries, which are in major decline, is beyond the scope of this chapter.

Oxygen Depletion?

Oxygen is ubiquitous at around 47% by weight of crustal earth. Like carbon it is substantially present in a combined form because of their importance in reduction and oxidation processes.

There is a lot of it – some 600 moles above every square metre and 250 moles below in the oceans.

⁵ By dividing my the atomic weight of carbon (12.01) and multiplying my the molecular weight of CO₂ (44.01)

The stoichiometry of the reactions



and

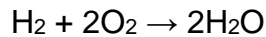

suggest that with the burning of fossil fuels or hydrogen the level of oxygen in the atmosphere should be declining.

According to recent studies such as that conducted by Ray Langenfelds from CSIRO Atmospheric Research this is the case. Langenfelds showed a .03% reduction in oxygen levels in just 20 years using air samples taken from Cape Grim in remote Western Tasmania (Langenfelds, R., 2003). The level as at the date of the study was 20.92%, down from 20.95% 20 years earlier.

According to scientist Richard Matear from CSIRO Marine a recent series of experiments showed a decline in the level of oxygen at between 500 and 1500 metres in samples taken from the great southern ocean taken from the Aurora Australis between Tasmania and Antarctica (Matear, R., 2002).

The decline at about .0015% (or about 3 ppm out of 209,500 ppm) per year is very slight and much less than the stoichiometry of the above equation predicts and this is thought to be because of biological catch up.

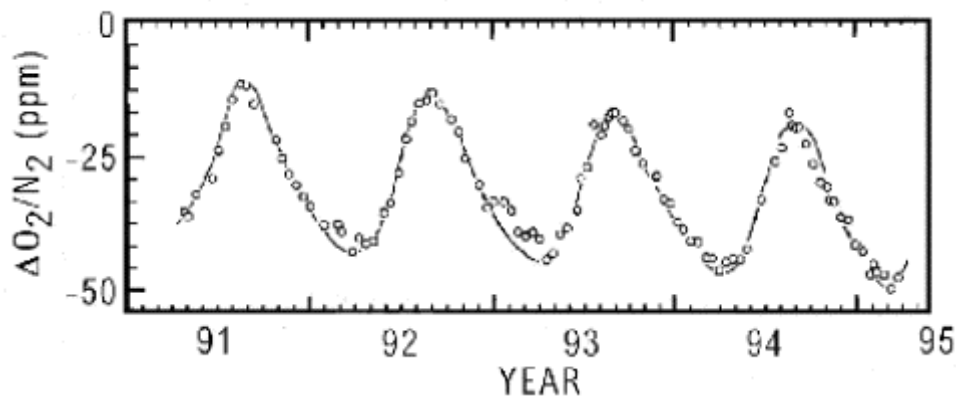

Figure 8 - Oxygen Depletion (Unofficially released data from a Northern Hemisphere Sampling Station - No References Available!)

The above anonymous illustration shows the oxygen concentration fluctuating about 30 ppm throughout the year (relative to nitrogen gas) and an annual depletion of 3 - 4 ppm superimposed upon the annual cycle.

The figure given in most text books for the level of oxygen in the air is 20.95%, however studies supporting this were conducted prior to 1965. In pristine and isolated places the figure today is more like 20.92% as found by the CSIRO in remote western Tasmania. In more populated areas where land has been cleared the average figure has fallen to more like 19% or 20%. In some cities (where the majority of the world's population live) the level is even

lower due to consumption, higher levels of CO₂ and pollution and figures as low as 12-18% have been recorded. As 7% is considered starvation level and some 90% of the world's population live in cities, this is concerning.

What is the optimal level of oxygen? Field geologists have found that the evidence from small pockets of air trapped in fossilised amber that the level of oxygen some 80 million years ago was somewhat higher at around 30% - was that an optimal level and has it been falling since then?

More research obviously needs to be done in this area and made public. It is also important when considering emissions and sequestration to not only consider the affects on CO₂ emissions but on O₂ depletion as well.

TecEco, my company has uniquely proposed changing the carbon cycle by using carbon as a major component of the built environment. The modifications proposed by TecEco include a kiln technology that allows the capture of CO₂ for geological sequestration and a way of using CO₂ to concretes, a major component of construction. See Eco-Cement on page 58 and Figure 29 - The Carbon Cycle as TecEco Would Like to Modify It (Adapted from Kimball (Kimball, J. W., 2004))

Biomimicry

The term biomimicry was popularised by the book of the same name written by Janine Benyus (Benyus, J. M., 1997) and is a method of solving problems that uses natural processes and systems as a source of knowledge and inspiration. It involves nature as model, measure and mentor.

The theory behind biomimicry is that natural processes and systems have evolved over several billion years through a process of research and development commonly referred to as evolution. A re-occurring theme in natural systems is the cyclical flow of matter in such a way that there is no waste. This concept can be represented by the simple formula: waste = food indicating that anything coming to the end of its useful life becomes food for something else.



Figure 9 - Biomimicry - Houses of Carbon

Currently the world's carbon cycle is out of balance because the waste of fossil fuel burning (CO₂) is not being utilised as a fuel/food for other processes. TecEco have addressed this issue with their eco-cements by using carbon as an element of the built environment and for wastes by utilising them for their physical property rather than chemical composition.

The Techno - Process

According to the American Association for the Advancement of Science Population and Environment Atlas (AAAS, 2004), "Consumption and technology impact on the environment by way of two major types of human activity.

First, we use resources. We occupy or pre-empt the use of space, and so modify or remove entirely the habitats of many wild species. We extract or take resources - growing food, catching fish, mining minerals, pumping groundwater or oil. This affects the stock of resources available for humans and for other species in the future.

Second, we dump wastes - not just those that consumers throw away, but all the waste solids, liquids and gases that are generated from raw material to final product. These affect the state of land, groundwater, rivers, oceans, atmosphere and climate."

These activities are essentially the take and waste impacts of what I shall call the techno – process⁶ which describes our primitive and unconnected industrial metabolism and the linear flow of matter through our economy.

Take → Manipulate → Make → Use → Waste

The techno-process is a mostly enterprise based linear process of extracting resources, manipulating them as required (modifying substances), making something with them, using what is made and then throwing away what no longer has utility⁷.

The impact of the techno – process on the planet is significant. Resources are not unlimited and the planet does not have an infinite capacity to reabsorb wastes.

Given the diverse nature and huge scale of the techno-process and the many linkages of this process to the geosphere-biosphere any solution will involve doing something in all ways possible at all stages of the techno-process from take to waste and involve a large number of people, professions and industries.

⁶ Also variously called the materials supply or materials cycle, industrial metabolism etc.

⁷ Utility is an economic term for value to the user.

To allow us to live more equitably and sustainably within the means of the planet and possibly even for our own long term survival take and waste impacts need to be reduced and preferably eliminated to what is renewable and preferably biodegradable. Embracing philosophical catchwords are Reducing, Re-using, Recycling and Recovering.

"Zero waste is a philosophy and a design principle for the 21st Century; it is not simply about putting an end to landfilling. Aiming for zero waste is not an end-of-pipe solution. That is why it heralds fundamental change. Aiming for zero waste means designing products and packaging with reuse and recycling in mind. It means ending subsidies for wasting. It means closing the gap between landfill prices and their true costs. It means making manufacturers take responsibility for the entire lifecycle of their products and packaging. Zero waste efforts, just like recycling efforts before, will change the face of solid waste management in the future. Instead of managing wastes, we will manage resources and strive to eliminate waste." (GRRN, 2000)

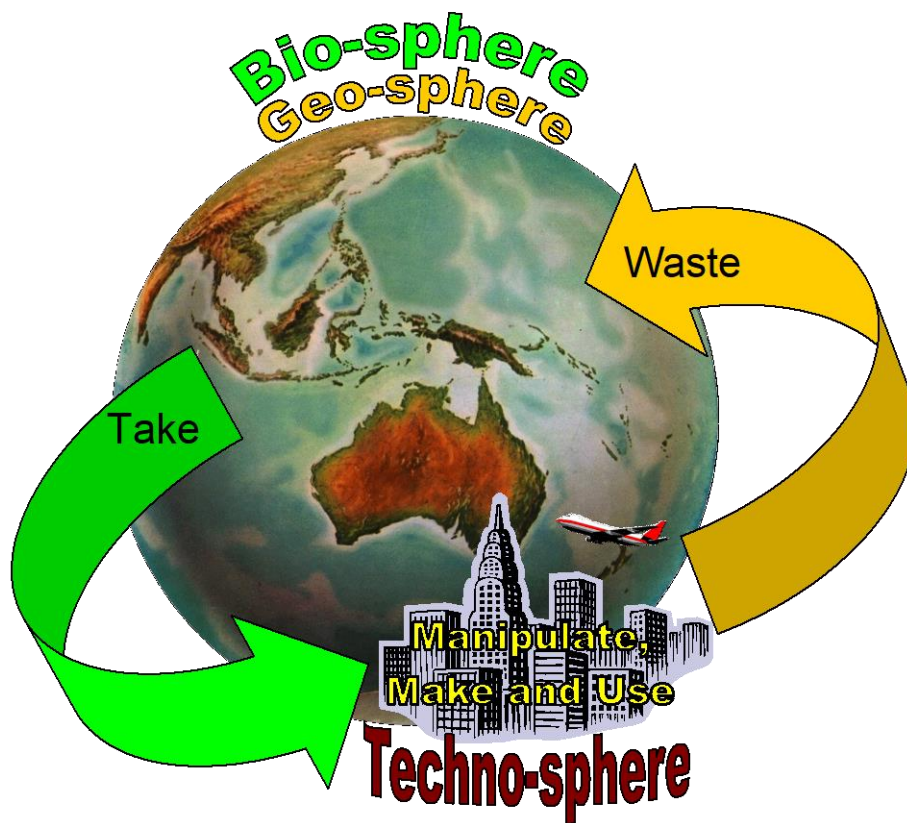

Our linkages to the geosphere-biosphere are defined by techno processes describing and controlling the flow of matter and energy. It is these flows that have detrimental linkages to earth systems.

Figure 10 - The Techno-process

There is no doubt that in the past technology has been a major player and at the root of much of the problem. It is time for science to balance the ledger in the form of new sources of energy and new materials with a much lower impact that solve issues such as global warming, climate change and waste because they change the molecular flows that are harming the planet.

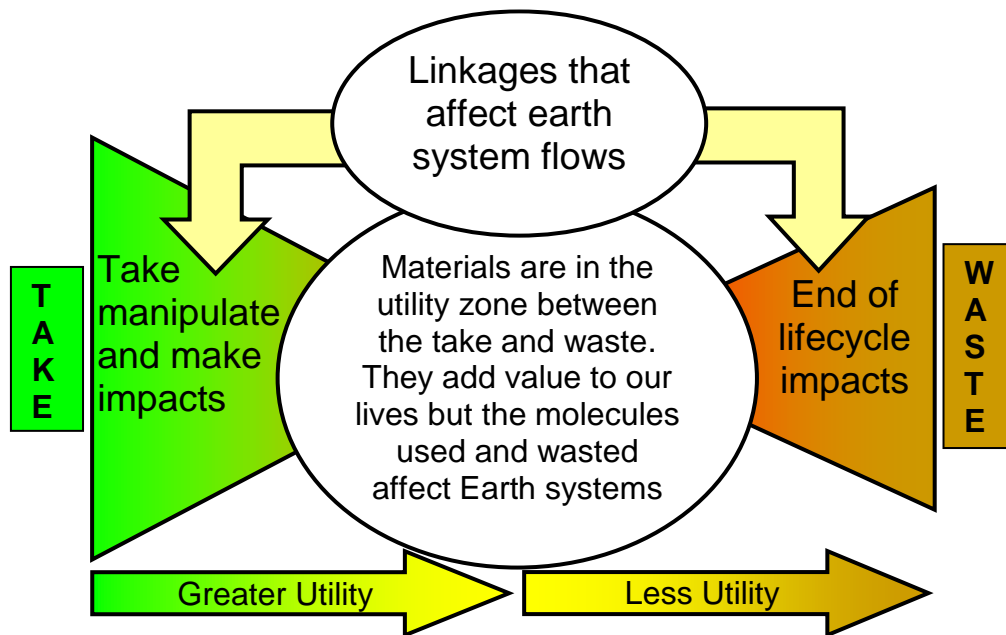

Figure 11 - Materials and the Take and Waste Impacts of the Techno-Process

The techno-process is powered by fossil fuel and reversing damaging underlying molecular flows associated with it such as the accumulation of CO₂ will best be achieved using non fossil based energy such as solar or energy directly derived from solar such as wind or wave.

The techno process has delivered large quantities of a smorgasbord of unnatural materials with impacts at every step of the process. There is waste in the process and at the end of it. It is therefore fundamental that we think about the materials we use and the molecules they are made of.

The Importance of Materials

Materials are everything between the take and waste. They are fundamental to the techno-process and determine many properties including weight, embodied energies, fuel related and chemical emissions, lifetime energies, user comfort and health, use of recycled wastes, durability, recyclability and the properties of wastes returned to the geosphere-biosphere.

Resources extracted from the geosphere-biosphere can be classified broadly into several non exclusive types. They are short or longer use, biologically or geologically derived, surface or sub surface etc. but most of these classifications are less relevant to sustainability than the extent to which resources are renewable or not renewable.

The techno-process is very inefficient in that large quantities of renewable and non renewable resources are extracted to produce small quantities of materials which themselves are used to produce even smaller volumes of

things actually used, many of which do not retain utility⁸ very long before they are in turn thrown away. There is no such place as away.

“The global flow of matter, some 500 billion tons per year, most of it wasted, is largely invisible. Yet obtaining, moving, using, and disposing of it is steadily undermining the health of the planet, which is showing ever greater signs of stress, even of biological breakdown. (Hawken, P., Lovins, A. et al., 2000)

Examples abound. One study found that around 93 percent of materials used in production do not end up in saleable products but in waste, while 80 percent of products produced are discarded after a single use (Von Weizsäcker, E. U., Lovins, A. B. et al., 1997).

Some excellent examples of this wasteful process are given by David Schaller (Schaller, D., 2004) for organic materials and foods.

Mining is a major culprit as it involves the extraction of a non renewable resource, the processing of significant volumes of material for a small quantity of end product as most substances being mined are present only in small percentages, the rest being discarded as tailings.

Consider a one litre tin of white paint that will cover 16 m² of wall. During its manufacture 360g of synthetic rutile, 95g of chlorine, 118g of petroleum coke, 235g of oxygen, 350g of nitrogen, 60g of carbon, 60g of lime, 9 litres of water and 20 MJ of energy were used and 28 kg of rock, sand and clay were moved (Herbertson, J. and Green, M., 2003)

Another example is the high proportion of new materials delivered to construction sites that are wasted.

Some studies show that between a half and three-fourths of the materials used in our industrial economy are generated and treated as waste before ever entering the economy. They are not seen or treated as commodities and aren't valued as such (Schaller, D., 2004)

Materials contain undesirable concentrations of substances dangerous to the environment and many are wasted throughout the techno-process. Some when wasted have dangerous impacts. To reduce linkages to the geosphere-biosphere it is essential we reduce the throughput and impact of the techno-process. The incentive is that economically we would be better off.

Impacts

In recent decades many environmental indicators have moved outside the range in which they have varied for the past half a million years. We are altering our life support system and potentially pushing the planet into a far less productive state.

⁸ value to us.

"The world faces significant environmental problems: shortages of clean and accessible freshwater, degradation of terrestrial and aquatic ecosystems, increases in soil erosion, loss of biodiversity, changes in the chemistry of the atmosphere, declines in fisheries, and the possibility of significant changes in climate. These changes are occurring over and above the stresses imposed by the natural variability of a dynamic planet and are intersecting with the effects of past and existing patterns of conflict, poverty, disease, and malnutrition (Steffen, W. and Tyson, P., 2001)."

Take Effects of the Techno-Process

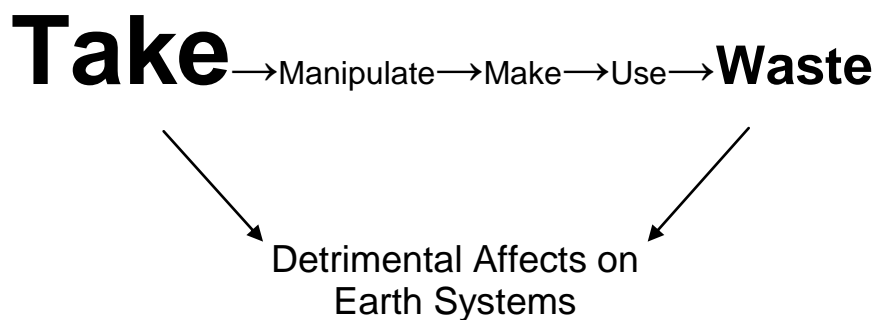

In the past the main cause of concern was that resources would not be sufficient to sustain the human race let alone the techno-process (even if it was not called that) "Frequent warnings were issued that we faced massive famines, or that we would "run out" of essential fuels and minerals (AAAS, 2004)."

The first and most well known to predict such gloom and doom was Thomas Malthus who wrote numerous papers on the subject including "An Essay on the Principle of Population (Malthus, T., 1798)" predicting widespread food shortages with increases in population.

Neo Malthusians believe that increases in population will eventually degrade environmental resources leading to devastation. They may yet be right. Until the last few decades there was little evidence of population growth associated with resource consumption being limited by the supply of resources mainly due to the input of technology and market forces which improved discovery, extraction and production.

When a particular mineral for example looked like it may be becoming scarce market forces drove the price up encouraging further exploration and the discovery of new deposits. This process of new discovery has recently come under considerable pressure. Oil production and reserves for example are now though to be near climax and set to fall. (See Figure 14 - Oil And Gas Liquids 2004 Scenario - Updated by Colin J. Campbell, 15 April 2004, for the ASPO web site (Campbell, C., 2004) on page 25.

Renewable resources such as water, fish stocks, even the air we breathe are today of much greater concern because they are now understood to be much more fragile and influenced strongly by overuse and pollution

Waste Effects of the Techno-Process

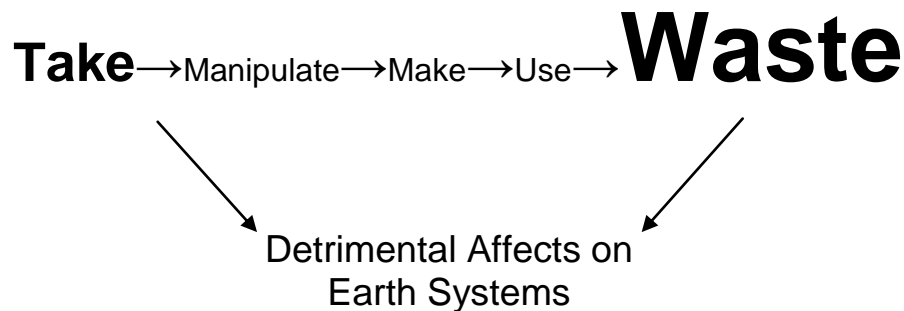

Of major concern is the problem of wastes created in producing and consuming resources. Wastes are the output of the techno-process; some are insidious poisons that are distributed in the global commons as discussed above under the heading Biosphere Impacts on page 29, others are not so dangerous to life but their sheer volume presents problems.

In the mid-1990s for example countries belonging to the OECD produced 1.5 billion tons of industrial waste and 579 million tons of municipal waste -- an annual total of almost 2 tons of waste for every person (AAAS, 2004). OECD countries produce much more waste per capita than underdeveloped countries in which by necessity the peoples tend to live more holistically and in harmony with nature.

A high proportion of wastes is from construction and demolition activities. A waste audit in South Australia in 1998 found "53.1% by weight of the waste South Australians send to landfill is generated from construction and demolition activity (including waste fill). Waste materials in this category include concrete, bricks, tiles, steel, glass, metal, wood, asphalt and plastics. Domestic waste comprised 27.5% by weight of waste sent to landfill and commercial and industrial waste comprised 15.7% by weight. Around three-quarters of commercial and industrial waste is comprised of garbages, food/kitchen waste, cardboard, paper, wood, and plastic bags/film (Dept. Environment and Heritage, S.A. Govt. Annual Amount and Composition of Waste Consigned to Landfill, 2004)." Many of these wastes are potentially recyclable.

According to Maria Atkinson of the Green Building Council of Australia the figure nationally of waste going to landfill from construction and deconstruction activities (predominantly the churn of refurbishments) was around 40% (Atkinson, M., 2003).

The figures for building materials in waste streams vary around the globe and one of the problems is that the method in which audits are conducted also varies making it hard to obtain comparative statistics.

The flow of unwanted or waste materials is affecting our planet. The solid wastes that are not incinerated generally go to landfill and pollute water courses and the local area. Liquid and gaseous pollutants are more insidious and spread invisibly in the global commons.

Landfill

Landfill is the technical term for filling large holes in the ground with waste. These holes may be specially excavated for the purpose, may be old quarries, mine shafts and even railway cuttings. More recently mountains or islands made of waste are being created.

Apart from wasting what are potentially resources landfill sites produce climate changing gases such as methane which is some 25 - 27 times more powerful than CO₂ as a greenhouse gas but only remains in the atmosphere for about ten years and so loses its greenhouse effect quickly compared to CO₂ which remains in the atmosphere significantly longer.

The current atmospheric concentration of methane is 1.8 ppm or $25 \times 1.8 = 45$ ppm CO₂ equivalent. This is 12% of CO₂ concentration and its growing 2.5 times as fast (University of Oregon, Electronic Universe Educational Server, 2004). The current concentration of CO₂ on the other hand is around 370 ppm.

Landfill can cause ill health in the area, lead to the contamination of land, underground water, streams and coastal waters and gives rise to various nuisances including increased traffic, noise, odours, smoke, dust, litter and pests.

“The real cost of dumping is not borne by the producer of the waste or the disposer, but by the people whose health and property values are destroyed when wastes migrate onto their property and by the taxpayers who clean it up (Sanjour, W., 2001)”.



Landfill is the technical term for filling large holes in the ground with waste. Landfills release methane, can cause ill health in the area, lead to the contamination of land, underground water, streams and coastal waters and give rise to various nuisances including increased traffic, noise, odours, smoke, dust, litter and pests.

Figure 12 - Landfill - The Visible Legacy of not Recycling

Recently the headline in the Mercury, a local Tasmanian newspaper said “Call for Landfill Cancer Enquiry (The Mercury2004) The paper went on to say that “The site of an old Hobart landfill should be tested for groundwater contamination after a number of cancers have been discovered in the area over 30 years....The opposition first pushed for testing of the old tip last June and renewed its call this month after the release of the State of the Environment Report. This said that 100 of Tasmania’s 176 landfill sites may have contaminated ground water....The potential damages to an ecosystem or to a community’s health can be significant and the costs of cleaning up the site can be high.... A Department of Mineral Resources study in 2002 examined 10 tip sites and found potentially dangerous groundwater contamination in six.”

According to the EPA “Resources that simply become waste are not available for future generations and extraction and harvesting of additional resources can have long term environmental impacts. Even as we implement protective waste management programs, toxic chemicals can still find their way into the environment throughout the life cycle of materials in extraction, production, transportation, use, and reuse. Persistent, bio accumulative and toxic chemicals released into the environment can present long term risks to human health and the environment, even when released in small quantities (EPA, 2003)”.

Combined Impacts

Most techno-processes have combined impacts at both the take and waste end. Consider some of the larger materials flows:

Resource Use Impacts

There is an explosion of substances through the techno-process many of which have damaging linkages with the geosphere-biosphere associated with them.

Examples abound of the use of resources we extract from the planet that result in unsustainable linkages. Mentioned above was the example of a modern paint. Global warming is the biggest problem and the major contribution from fossil fuel burning, cement production and gas flaring during the period 1751 to 2000 is shown in Figure 13 below.

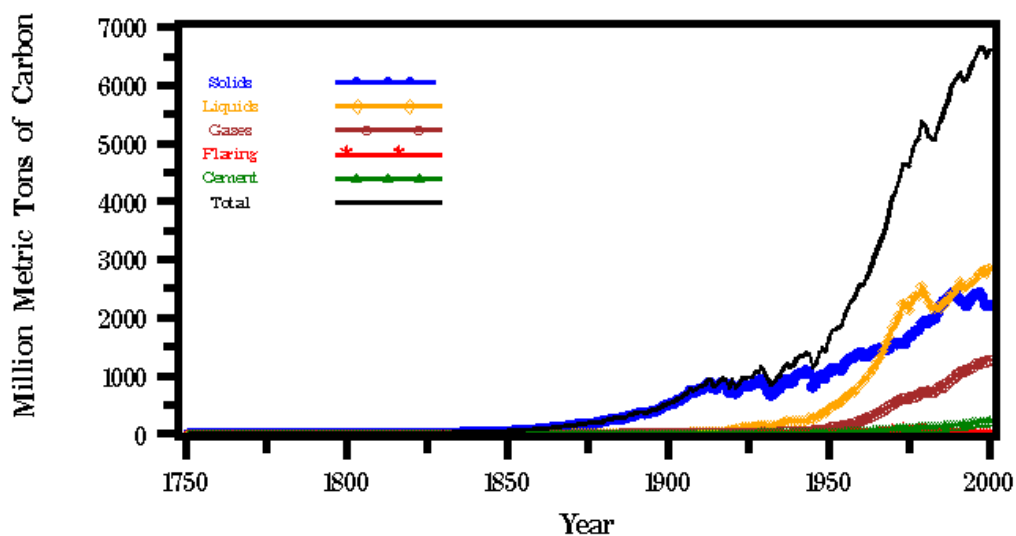

Figure 13 - Global CO₂ Emissions from Fossil Fuel Burning, Cement Production, and Gas Flaring for 1751-2000 (Marland, G., Boden, T. A. et al., 2003).

The growth of energy consumption is closely correlated with increases in gross national product which is a measure of economic development. The current consumption patterns of fossil fuels, as well as contributing to emissions, is not sustainable and neither is the production of cement (See Cement Production on page 26.) The emissions from the burning of fossil fuels and production of cement are shown in Figure 13.

Fossil Fuels

Fossil fuels are at the root of many of our problems, they powered the industrial revolution which attracted millions from self sufficiency in sustainable country and village economies to cities with factories that were superficially more efficient but not in a holistic or ecological sense.

Fossil fuels are not only a causal factor in the development of the environmentally damaging techno-process, from Figure 13 it can be seen that

burning them to produce energy is responsible for the greater proportion of anthropogenic⁹ emissions.

There is a strong need to kick the fossil fuel habit however this is unlikely to happen unless alternative sources of energy become more economical. This may be sooner than we think as “just under half of the world’s total endowment of oil and gas has been extracted already, and that output will begin to decline within the next five years, pushing prices up sharply (Campbell, C., 2002).” Most geologists however concur that thirty rather than five years is more likely.

OIL AND GAS LIQUIDS 2004 Scenario

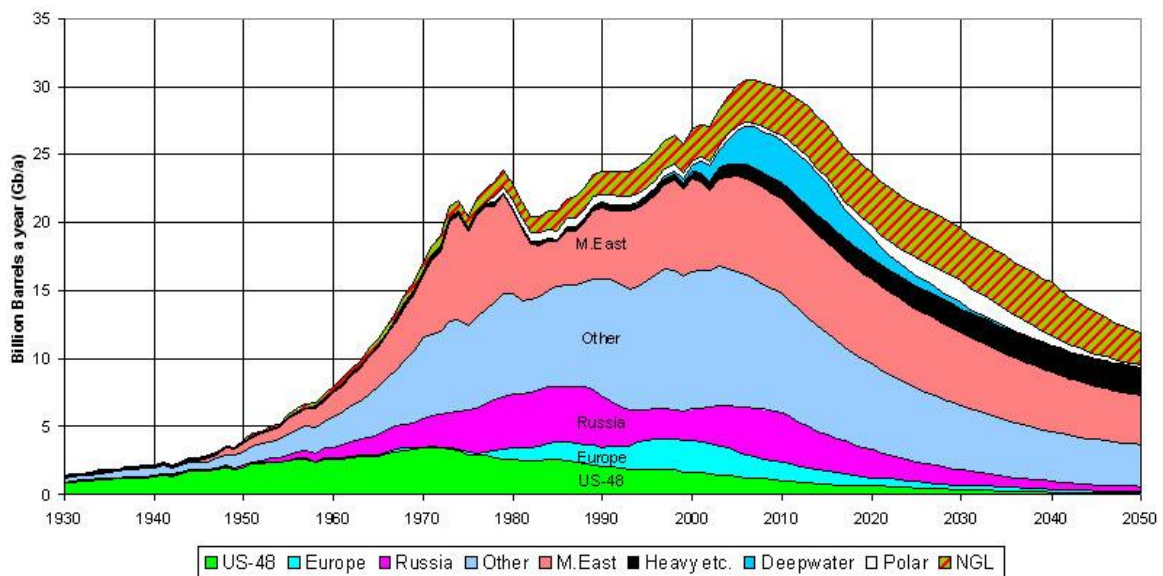

Figure 14 - Oil And Gas Liquids 2004 Scenario - Updated by Colin J. Campbell, 15 April 2004, for the ASPO web site (Campbell, C., 2004)

Even if we kick the fossil fuel habit before it kicks us, it will take centuries to bring the carbon balance back down to levels of the 50’s. Abatement and sequestration on a massive scale are essential. “Complementary to traditional areas of energy research, such as improving energy efficiency or shifting to renewable or nuclear energy sources, carbon sequestration will allow continued use of fossil energy, buying decades of time needed for transitioning into less carbon-intensive and more energy-efficient methods for generating energy in the future (NETL, 2004).”

It is encouraging that there is a slow shift to renewable energy as Figure 15 shows.

⁹ Anthropogenic – human sourced

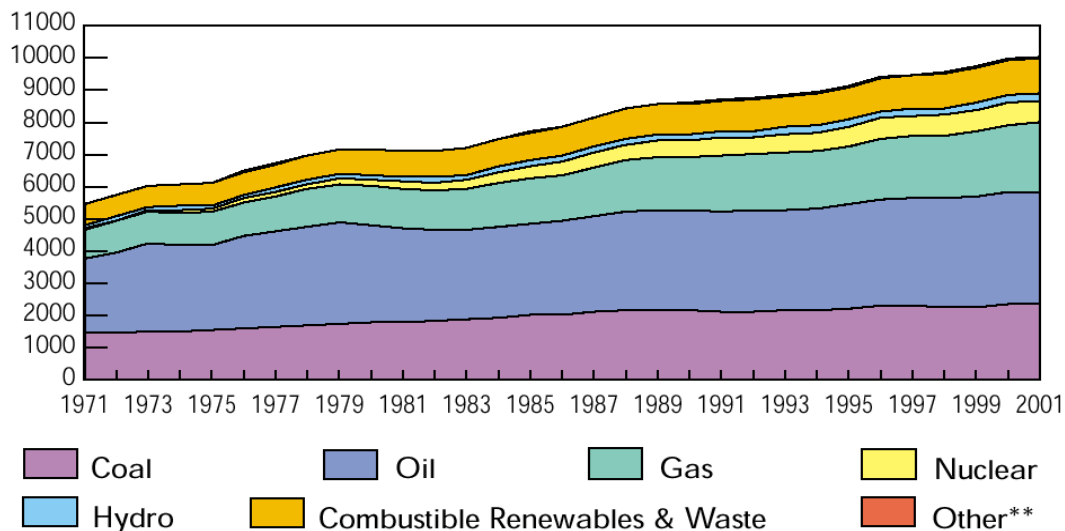

Figure 15 - Evolution from 1971 to 2001 of World Total Primary Energy Supply (IEA, 2003)

Australia is one of the biggest energy consumers per capita in the world and has tripled consumption in the past 20 years with 94% of our current energy consumption from fossil fuels (The Sunday Tasmanian 2001). As a consequence Australia contributes approximately 1.5% of the world total anthropogenic Greenhouse Gases. This however, represents 33.3 tonnes per capita emission for 1990, the highest of all the OECD countries, including the USA, which records the next highest emission of 23.0 tonnes per capita (Durie, R. A., 1998).

Cement Production

Another major source of CO₂ emissions is the production of cement. In 2003 the world produced 1.86 billion tons of cement (Van Oss, H., 2004) - about a quarter of a ton for every man, woman and child on Earth. Production is now probably well over 2 billion tonnes. Over 13 billion tonnes of concrete are the result which is over two tonnes per person per annum on the planet.

Contrary to lay understanding Portland cement concretes have low embodied energies and relatively high thermal capacity compared to other building materials such as aluminium and steel and are therefore relatively environmentally friendly.

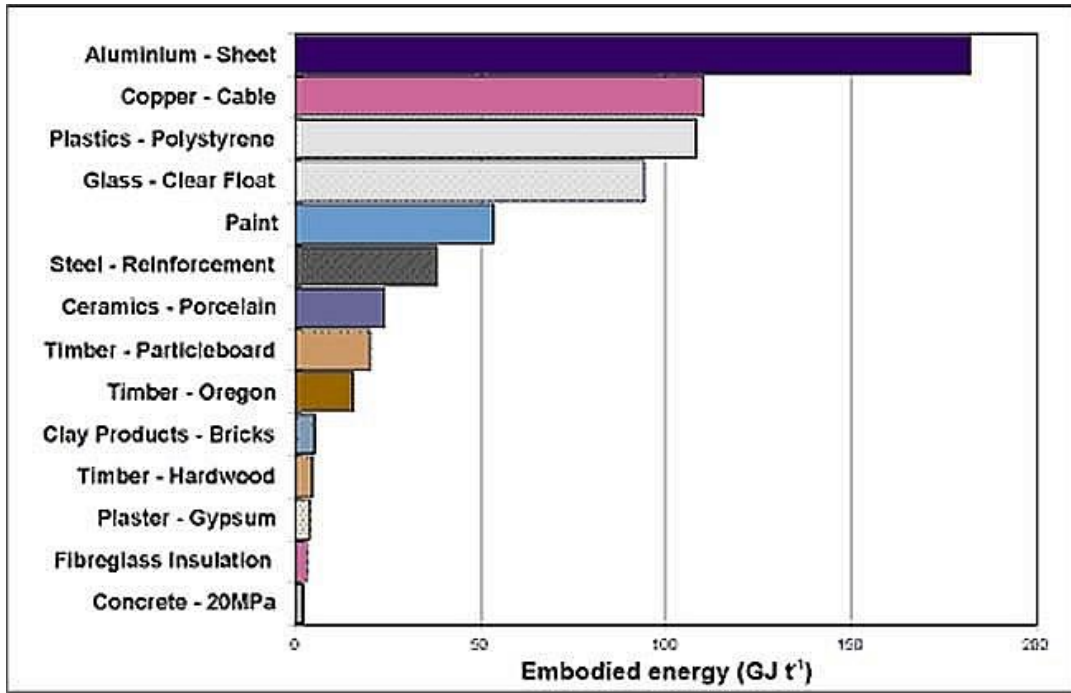

Figure 16 - Embodied Energy of Building Materials (Tucker, S., 2000)

However concrete, based mainly on Portland cement clinker, is the most widely used material on Earth.

As of 2004 some 2.00 billion tonnes of Portland Cement (OPC) were produced globally (USGS, 2004) (see Figure 17), enough to produce over 7 cubic km of concrete per year or over two tonnes or one cubic metre per person on the planet.

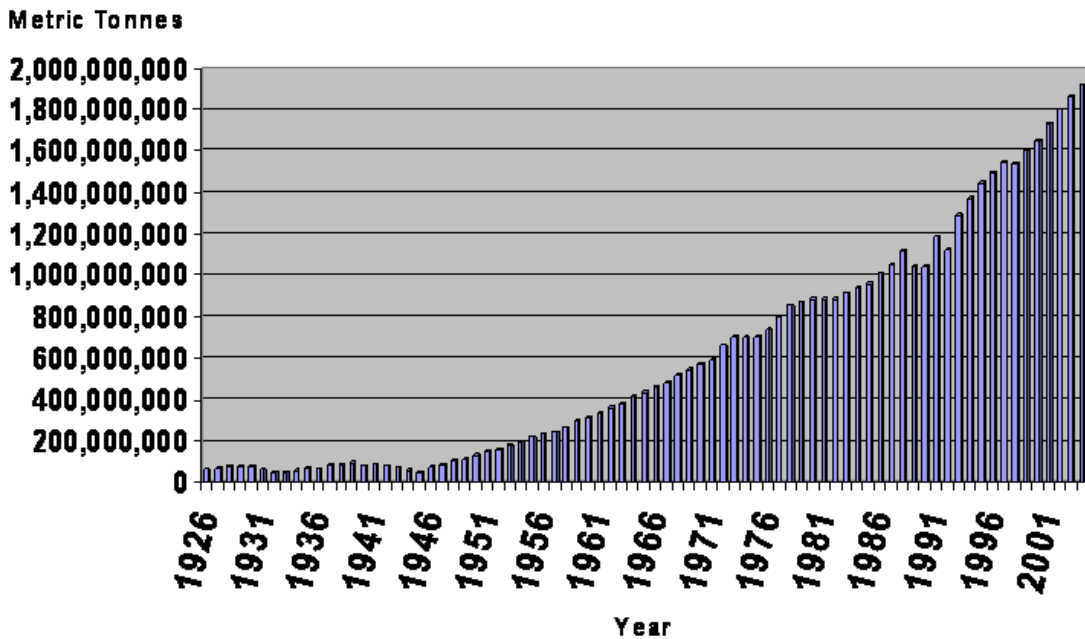

Figure 17 - Cement Production = Carbon Dioxide Emissions from Cement Production 1926-2002 (Van Oss, H., G., Hendriks, K. et al., 2003)

As a consequence of the huge volume of Portland cement manufactured, considerable energy is consumed (see Figure 18 - Embodied Energy in Buildings (Tucker, S., 2000)) resulting in CO₂ emissions. CO₂ is also released chemically from the calcination of limestone used in the manufacturing process.

Various figures are given in the literature for the intensity of carbon emission with Portland cement production and these range from 0.74 tonnes CO₂/tonne cement (Hendriks, C. A., Worrell, E. et al., 2002) to as high as 1.24 tonne determined by researchers at the Oak Ridge National Laboratories (Wilson, A., 1993) and 1.30 tonne (Tucker, S., 2002). The figure of one tonne of carbon dioxide for every tonne of Portland cement manufactured (Pearce, F., 1997) given by New Scientist Magazine is generally accepted.

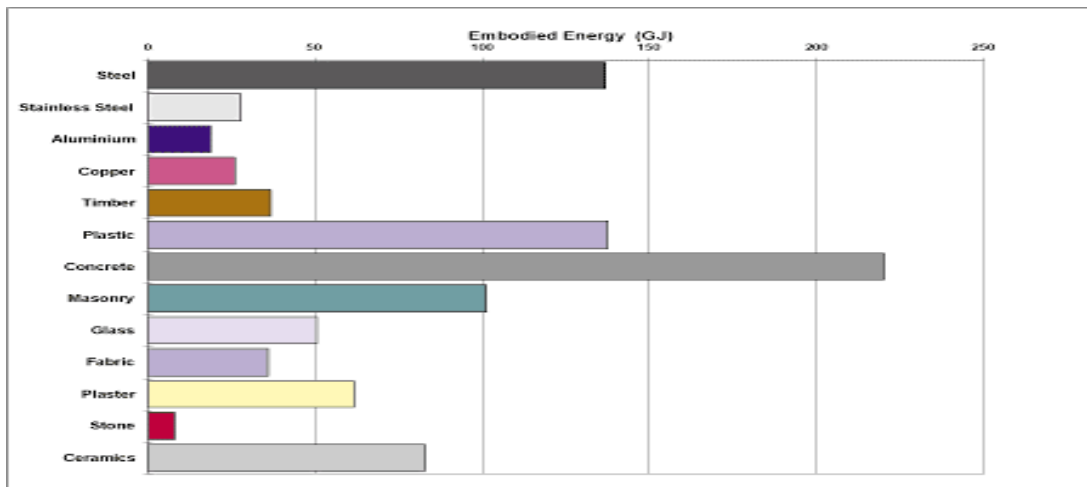

Figure 18 - Embodied Energy in Buildings (Tucker, S., 2000)

Because of the huge volume used, Portland cement concrete is the biggest single contributor to embodied energy in most buildings. As a consequence Portland cement concretes account for more embodied energy than any other material in the construction sector (Tucker, S., 2000). The manufacture of OPC is one the biggest single contributors to the greenhouse effect after the burning of fossil fuels, accounting for between 5% (Hendriks, C. A., Worrell, E. et al., 2002) and 10% (Pearce, F., 1997) of global anthropogenic CO₂ emissions.

Global production of cement is likely to increase significantly over the coming decades as:

- Global population grows;
- GDP grows¹⁰;
- Urban development continues; and
- Industrialisation increases.

¹⁰ Especially in China, India and other so called underdeveloped countries.

Associated with such huge usage and growing demand is the enormous potential for improvement in properties and sustainability.

New cements that may solve this problem are being developed by TecEco Pty Ltd based on blending magnesium oxide with other hydraulic cements. Magnesium is a small lightweight atom and its carbonates contain proportionally a lot of CO₂. TecEco have also designed a kiln that combines calcining and grinding in a closed system whereby CO₂ can be captured and geologically sequestered during manufacture. The carbonation that then occurs in TecEco eco-cement concretes used in the built environment equates to sequestration on a massive scale. As Fred Pearce reported in New Scientist Magazine (Pearce, F., 2002), "There is a way to make our city streets as green as the Amazon rainforest".

Biosphere Impacts

What distinguishes our planet from any other we have yet discovered is that there is life, comprising carbon based molecules which have evolved in a delicate balance with the rest of the atoms and molecules that make up planet earth.

Living matter is different from dead matter in that it contains genetic coding and has the ability to join and recombine atoms and molecules from the environment to build new replicates of itself for the future. This delicate balance is characterized by the flow of substances from the dead world to living matter and in reverse and has gone on for billions of years. Since the dawn of history and in particular the industrial revolution, our ability and willingness to manipulate everything around us has however wreaked havoc with living life forms in the biosphere.



Figure 19 - Most Pollution Eventually Makes it to our Waterways Killing Fish and other Life¹¹

¹¹ Microsoft Office 2003 clipart.

Seventy percent of Earth's coral reefs will cease to exist in the next forty years if the current warming trend continues. Every year, around one thousand (1,000) species are driven to extinction. The loss of tropical forests is especially alarming as they are the habitat of over fifty percent of the world's species of plants and animals. The list of impacts is a long one.

There is no doubt that we are seriously disturbing the "web of life" and evidence is mounting of worsening future problems unless we can reduce the impact of the take and waste associated with the techno-process.

Many of the transformed atoms and molecules produced as part of our techno-process activities are thrown "away", entering the global commons where they negatively affect our wellbeing and that of other living organisms on the planet. There is no such place as "away".

Persistent chemicals are not confined to the area in which they are disposed of. Gases like Chloro fluoro hydrocarbons (CFC's) move around in the atmosphere and are now found all over the globe.

CFC's were developed during the 1930s and found widespread application after World War II. They are halogenated hydrocarbons, mostly trichlorofluoromethane and dichlorodifluoromethane and were used extensively as aerosol-spray propellants, refrigerants, solvents, and foam-blowing agents because they were thought to be non-toxic. They are non-flammable and readily converted from a liquid to a gas and vice versa.

CFCs were however found to pose a serious environmental threat because in the stratosphere they broke down under ultraviolet light releasing chlorine which destroyed ozone. A hole over Antarctica developed in the ozone layer which shields living organisms on earth from the harmful effects of the sun's ultraviolet radiation.

"Because of a growing concern over stratospheric ozone depletion and its attendant dangers, a ban was imposed on the use of CFCs in aerosol-spray dispensers in the late 1970s by the United States, Canada, and the Scandinavian countries. In 1990, 93 nations agreed to end production of ozone-depleting chemicals by the end of the century, and in 1992 most of those same countries agreed to end their production of CFCs by 1996 (C-F-C.Com, 2004)."

Pollution by heavy metals is ubiquitous in the global commons and of particular concern. The term "heavy metal" refers to metals that are relatively high in density and toxic or poisonous even at low concentrations. Examples include mercury (Hg), cadmium (Cd), arsenic (As), chromium (Cr), thallium (Tl), and lead (Pb). They are particularly dangerous when released as wastes because they tend to bio-accumulate up the food chain. Marine organisms can for example consume a particularly dangerous form of mercury called methylmercury. When fish eat these organisms, the methylmercury is not excreted, but retained in bodily tissues. The older the fish and the more organisms further down the food chain they have consumed, the greater the amount of methylmercury in their tissues. The accumulated methylmercury is

concentrated as it is passed up the food chain and any organism at the top such as us faces a serious risk of mercury poisoning by eating such fish.

Heavy metals can enter water supplies from industrial and consumer waste, or even from acidic rain breaking down soils and releasing heavy metals into streams, lakes, rivers, and groundwater. We are constantly being alerted to the fact that living organisms in the far reaches of the globe contain significant traces of organic and metallic pollutants and that the deepest marine sediments, remotest glaciers and icecaps are contaminated. The list of contaminants is frightening and long.

Of even greater concern are radioactive wastes or accidental releases such as occurred at Chernobyl.

Change

If you want to truly understand something, try to change it. ~Kurt Lewin

He who rejects change is the architect of decay. The only human institution which rejects progress is the cemetery. ~Harold Wilson

Change is inevitable! In the case of the environment; desirable or we will go the way of the dinosaurs. Change is the solution.

The Need for Change

That earth systems are in trouble is evidenced by a variety of symptoms including global warming, pollution, salinity, loss of biodiversity and many others on a long list. The most frightening to our own survival is loss of oxygen in the atmosphere and increase in carbon dioxide causing global warming and significant climate change.

Climate change is in the news all the time. "Everybody is talking about the weather but nobody does anything about it (Twain, M.)."

Britain, Germany and one or two other countries are the only ones that appear to have grasped the significance of the problem.

According to the UK Hadley Center, most of the world's forests will begin to turn from sinks to sources - dying off and emitting carbon-by around 2040 (Gelbspan, R., 2004). Recently Robin Batterham, Australia's chief scientist, said he supported the Federal Government's decision not to ratify the Kyoto Protocol on climate change because the reductions it set were not high enough. "I'm talking about enormous reductions - 80 per cent by the end of the century," Dr Batterham said. "Fifty per cent by 2050, I think, is realistic." (Batterham, R., 2004) and in the UK chief scientist Sir David King recently said that climate change is the biggest problem that civilisation has had to face in 5,000 years (Brown, P., 2004)

The scientific community and conservationists are now rigorously debating source reduction as the only available main option for ultimately reducing the Greenhouse effect. Even the USGS Commodities Annual 2000 has this to say on the cement pages (USGS, 2000).

“There continued to be concern over the environmental impact of cement manufacture, particularly the emissions of carbon dioxide and cement kiln dust (CKD).”

The recent opinion of Rajendra Pachauri, chairman of the United Nations' Intergovernmental Panel on Climate Change is that Kyoto looks like it is a treaty but goes nowhere near far enough (Doyle, A., 2004).

In a recent book Meyer Hillman has proposed carbon rationing as the only viable means to keep the carbon dioxide concentration in the atmosphere below 450 ppm (Hillman, M. and Fawcett, T., 2004).

Others believe that abatement and sequestration on a massive scale are essential because we will not be able to free ourselves from the fossil fuel habit (NETL, 2004).”

It is important in all this discussion to discern what can realistically be achieved and what can not. As in dieting whereby weight loss is achieved most effectively by both exercise and reduction in the consumption of food; reductions in atmospheric carbon will best be achieved by action in all possible ways. Politically sequestration is the most acceptable as it does not involve one person, state or country attempting to regulate the consumption of carbon by another, for which force will ultimately be required.

Who or what is to blame? – are there just too many of us or shall we blame technology? Is technology the culprit or a potential saviour? Or are we guilty through our naivety in using all that consumerism post the industrial revolution has delivered us. Is there any way out of this dilemma? Can the industrial juggernaut we have unleashed deliver more sustainable outcomes?

Village and tribal economies of yesteryear and still prevalent in some third world countries were actually very sustainable. Everybody had a role and all were interested in the ability of the surrounding area to sustainably continue to produce. One of my first supporters and an early shareholder, Bob Johannes a marine scientist and Pew fellow wrote a classic text book about island ecologies/economies centred on marine life in a lagoon (Johannes, R., Earle, 1992). For centuries the people on the island lived in harmony with nature. They managed to live well without fridges and washing machines and all the other trappings of modern life. Do we have to dematerialise to quite such an extent to live more sustainably or can we preserve some of the trappings of modern living we are addicted to? I can't answer all these questions but I do think we can live more sustainably without affecting our lifestyles too much and this chapter is about how. The bad news is that it would help if we could curb our population growth and dematerialise/ de-energise to some extent!

The bottom line is that population along with consumption and technology are factors in waste and pollution. It is not population growth per se that is the culprit however; it is the increase in flows through the techno-process previously defined. The consumption of resources and level of production of wastes or pollutants impact on the environment. The severity of impact is a function of the number of people, the amount each person consumes, and the amount of waste created in the whole process from extraction, production and packaging to the consumer and his or her dustbin or sewage outlet.

Several efforts have been made to put numbers on the relative share of responsibility for the rising impacts and pollution. Environmentalist Barry Commoner studied examples from the United States between 1946 and 1968. Population growth accounted for only 14 to 18 percent of the increase in synthetic organic pesticides, in nitrogen oxides and in tetraethyl lead from vehicles. It was responsible for only 7 percent of the increase in non-returnable beer bottles and a mere 3 percent of the increase in phosphorus from detergents. In almost every case, technology was the dominant factor. A later study by Commoner of nitrates, cars and electricity in 65 developing countries came to similar conclusions (Commoner, B., 1972).

On the other hand studies of changes in air pollutants (SO_2 , nitrogen oxides, smoke and CO_2) in countries of the Organisation for Economic Co-operation and Development (OECD) between 1970 and 1988 showed technology as a downward pressure in all four cases -- mainly through increased energy efficiency in the case of CO_2 and nitrogen oxides, and through cleaner technology in the case of SO_2 and smoke. Population growth was responsible for a quarter of the upward pressure on emissions, while consumption was responsible for three quarters (Harrison, P., 1992).

These studies substantially miss the point however. The answer is that we are to blame. It is true to say that less of us would produce less of a problem. It is also true to say that if we did not have the tools, devices and processes that technological advances have provided we would not have made quite such a mess of the planet.

So where to from this realisation? First understand human nature. We are unlikely to want to consume less or give up our cars and appliances. We are not going to dematerialise/de-energise and do without modern conveniences, transport etc. On the contrary, third world countries are rushing into materialisation/energisation at an alarming rate.

The answer is we must move technology into new and more sustainable paradigms that have a much lighter impact on the planet. A materials revolution particularly in the built environment that may well solve the problem is the most acceptable way. Lets take up the challenge and get on with it!

Getting over Barriers

Learned Helplessness

Is it possible that why we seem so unable to move forward in relation to global warming and other environmental issues is a learned helplessness (Seligman, M. E. P., 1990) in relation to what is an absurd consensus? Leith Sharp, of Harvard University (Sharp, L., 2003) says quite rightly "people are conditioned to conform to group perceptions and to doubt and withhold their individual perceptions if they are in conflict with the shared reality of those around them. This has enormous significance when considering how people are currently responding to the demise of the planetary systems that support human life. The degree of inaction around this profoundly life threatening situation can perhaps best be explained by viewing our state as a massive 'absurd consensus' that is the product of our social conditioning which has enforced our subservience to, and blind confidence in, shared societal constructs of reality."

What then is it that has conditioned so many of us to learn helplessness in the face of the absurd notion that the state of the planet and problems such as global warming are something we cannot do anything about?

Societies we live in today extol the virtues of the self. According to Prof. Seligman (Seligman, M. E. P., 1990) "in the past quarter century, events occurred that so weakened our commitment to larger entities as to leave us almost naked before the ordinary assaults of life." We have lost hope in the capacity in society to cure basic human ills and so in many ways have shifted our commitment to the self. Others call the age of rampant individualism we live in the "me" age.

Phillip Sutton, director, Policy and Strategy, Green Innovations Inc. says "we have not taken steps to mobilise people, we need to think very carefully about how the processes of imagination might be catalysed and how the mobilisation of people might be accomplished. What is blocking these processes, what is or might drive them forward? How can we trigger effective action?" (Sutton, P., 2002)

The media have a vital role in conditioning us all to believe that global warming and environmental problems are not inevitable and that we should and can do something about it.

With the Help of the Media

Public understanding of climate change and other environmental problems is very important and conditioned by the media. People need convincing that they can do something about global environmental problems and that they must get on with it.

The mass media plays a central role in the formation of opinions and images about climate change. The coverage by the press, radio and television of climate change and other environmental issues and how readers, listeners

and viewers receive and process the information delivered to them is very important.

Social responses to climate change and other environmental issues are not exclusively determined by scientific knowledge. On the contrary, the media has an interpretive role. Using social actors in complex communication processes the cultural meaning of such environmental phenomena is shaped. Public perceptions of social risk evolve as a result of diverse patterns of interpretation from experts, policymakers, journalists and citizens. These risk constructs are regulated by culturally specific decision-making processes. The analysis of societies' ability to adjust to global climate change and how scientific knowledge is integrated in social and individual sense-making about environmental issues relies on knowledge about these interpretative processes.

The goodwill of the media is essential. Players in the media must take seriously their important role of conditioning people to action on sustainability. By exalting the achievements of our environmental entrepreneurs, instilling a philosophy of "can do" and extolling us all to work for sustainability the media can help lead us away from threats to our very survival.

And Educationalists

Our teachers have an important role as well. We must learn from the outset the value of and how to relate to the environment and a "can do, can fix" attitude.

"Education not only provides the scientific and technical skills required, it also provides the motivation, justification, and social support for pursuing and applying them. Education increases the capacities of people to transform their visions of society into operational realities. It is for this reason that education is the primary agent of transformation towards sustainable development. It is also for this reason that society must be deeply concerned that much of the education presently on offer falls far short of what is required. Improving the quality and coverage of education and reorienting its goals to recognize the importance of sustainable development must be among society's highest priorities."(UNESCO, 2004)

Imperfect Markets

Markets exist for the exchange of goods and ideas, but is the long term view required for sustainability likely to cause changes in the way they operate? According to Fiona Wain from Environment Business Australia (Wain, F., 2004) "there is a school of thought which promotes the concept that human intellect will invent new technologies to avert disaster. But human ingenuity relies on market demand, and markets fail the system completely when they cannot respond quickly to threats that are *perceived* as slow and insidious.

In order for technology to provide solutions to environmental challenges two things must happen:

- The market must receive signals that relate to current challenges; the need for change; and the value of innovation
- The market must then pull that innovation through by championing its value

this in turn attracts investment and creates the longer term framework for amortisation and profit which in their turn encourage further R&D and benchmarking.”

Fiona Wain is right in so far as new technologies will help us avert disaster. Because to some extent sustainability and resource efficiency are the same thing I do not however believe her pessimistic view of what markets can deliver is justified.

Due to the imperfections of markets including their inability to in part recognize the value of sustainability, see across technical paradigms and toward the longer term that there is a role for governments to intervene in markets to at least set trends.

Economies of Scale

Economies of scale were discovered by the likes of Henry Ford and remain as a difficult barrier for any new technology or player in the industry to overcome. Arguably economies of scale are as large a barrier as the formula based standards that support the status quo.

To nurture new technologies a level playing field and incentives are required. As it is the role of governments to govern for the common good providing such business conditions is their prerogative. (See Appendix 1. on page 79)

Even though governments through policy can introduce change that brings about economies of scale it is important that building technologies that seek sustainability are also eventually fundamentally economically viable.

Given long run economies of scale the new calcium-magnesium cements from TecEco are more economic as well as better for the environment.

Other Economic Barriers to Innovation and Market Entry

Economic Barriers to Innovation and Market Entry including the high cost of manufacturing plant and equipment, monopolistic and oligopolistic behaviours, transport costs etc.

Barriers in the Construction Industry

The construction industry has inherent characteristics that restrict the rate of adoption of new technologies required to meet the challenges of the future and achieve greater sustainability. These include:

- Conservatism, industry dogmatism and culture

- Formula based standards
- Expensive manufacturing infrastructure.
- Low margin product.
- Economic barriers to innovation and market entry.

Conservatism, Dogmatism and Culture

Buildings and construction methods have not changed all that much since the times of the Romans and in the past when they have changed they have not changes quickly. New technologies are usually slow to be adopted and this conservatism is entrenched in modern day time by a culture of litigation and fault finding inducing a fear of change.

Engineers also tend to think within a standards framework and not beyond. There is a saying in the industry that nobody gets fired for specifying bricks and mortar. In regional areas thing tend to get done in certain ways and there are definite differences from country to country.

Sustainability in construction does not mean loss of cultural influence and dogmatism should never stand in the way of common sense.

Formula or Prescription Based Standards

If the construction industry is to play a major role then it must shake off the shackles of the past and innovate. To do this it will have to abandon the formula-based approach to standards which grew out of the industrial environment of the early twentieth century. Standards are important for the protection of people, but if prescription based, stifle creativity. Why the industry is so bound to prescription based standards from the past must be questioned. Performance based standards make much more sense.

National governments can force change by legislating for performance based standards. If they did, innovation would return to reward us with much more rapid change towards sustainability.

Expensive Manufacturing Infrastructure

Infrastructure is expensive and particularly expensive in the business of manufacturing for construction. Plant for brick making, timber and plywood products, cement and so on costs a lot of money and the consequence is a cost barrier for change.

Low Margin Product

Cement, bricks and many other basic materials used in construction tend to be standardized, with little distinction between one brand and another. The result is price competition and low margins.

The Economics of Change Towards Sustainability

Our understanding of the flows and interactions in the global commons is very inadequate. The widely held view is that sustainable management strategies are complex to devise and politically difficult to introduce.

It is important in all this discussion to discern what can realistically be achieved and what can not. As in dieting whereby weight loss is achieved most affectively by both exercise and reduction in the consumption of food; reductions in atmospheric carbon and other reductions in our impact will best be achieved by action in all possible ways. In relation to global warming politically sequestration is the most acceptable as it does not involve one person, state or country attempting to regulate the consumption of carbon by another, for which force will ultimately be required.

What if sequestration and waste utilisation on a massive scale was economic? Underlying economic processes are human behaviours. What this mean is that if harnessed, human behaviour would deliver greater sustainability. How then can we achieve this?

Economics is both a servant and a master. Economic forces have been behind most wars and most people are slaves to economics, yet we can be the masters. Working for sustainability, market orientated forces will make all the difference as people would demand much more sustainable products.

The supply curve would shift to meet what was demanded and eventually a new more sustainable equilibrium would become established (See Figure 20 below). The challenge is how to move the supply and demand of resources towards more sustainable outcomes.

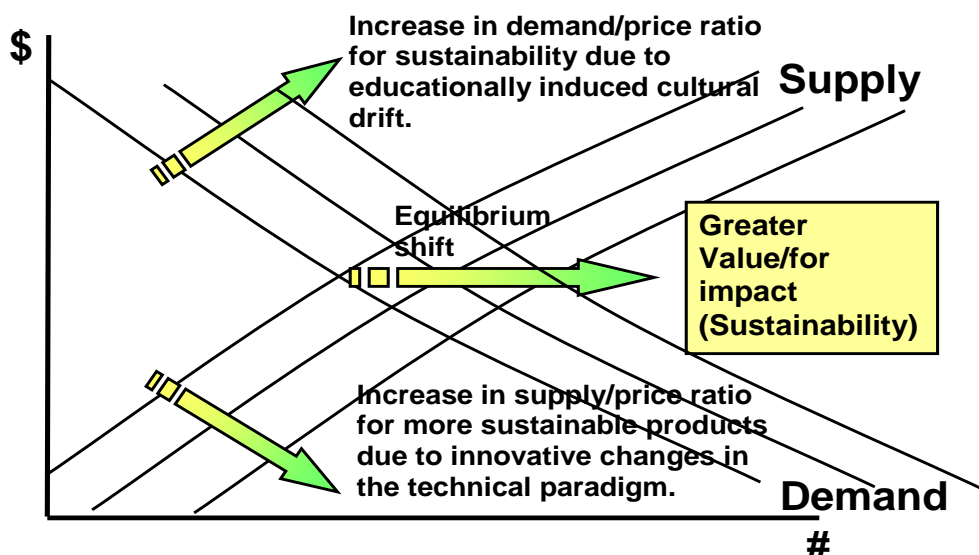

Figure 20 - Achieving Sustainability as an Economic Process

A systems approach would define more sustainable outcomes as being of greater value for less impact. Herbertson and Sutton in “Green Processing”

define value as meeting human needs economically and impacts as being harmful consequences for natural systems. (See Figure 21 below.

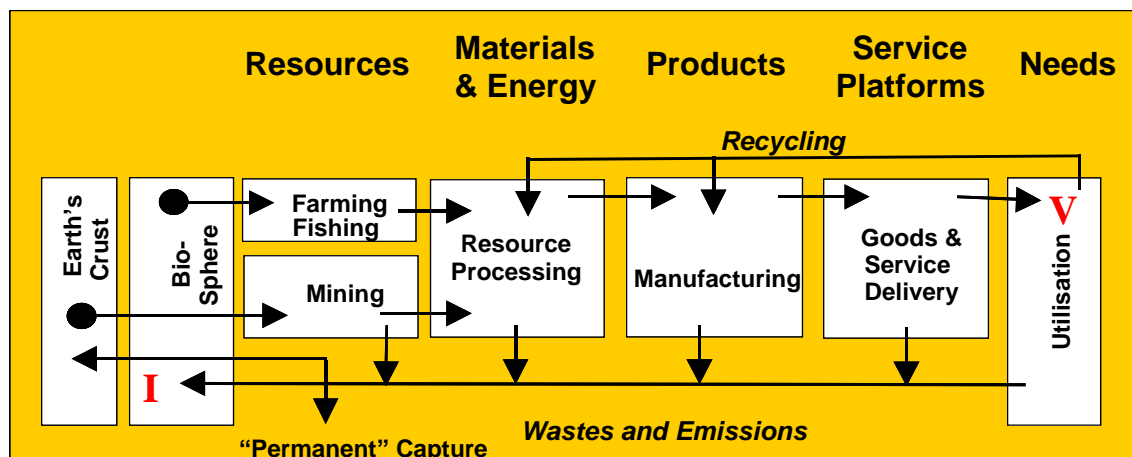

Figure 21 - A Systems Perspective of Value for Impact (V/I) (Herbertson, J. and Sutton, P., 2002)

To move towards economically driven sustainability we need to:

- Get over the idea that we are helpless and can't do anything about the problem and understand that sustainability is good business. (See Learned Helplessness on page 34 and 4. Sustainability is Good Business on page 67.)
- Cultural Change. As individuals demand sustainable products. As communities stimulate and harness human behaviours which underlay the demand for sustainable products. This can be achieved through cultural change push by the media, educationalists, governments and other leaders (See Cultural Change on page 39)
- Deliver more sustainable technologies through innovation (See Paradigm Shifts in Technology on page 40)

Drivers for Change

Apart from the need for sustainability there are other irresistible forces of inexorable magnitude that will force change.

Cultural Change

My experience so far is that it will be younger people who move the sustainability agenda forward. The greatest opportunity is in cities where architects and specifiers are leading the way. Many new developments are happening. I am for example involved with the Low Carbon Network and they have built some very innovative new sustainable structures.

The media and educators are working to help spread the word and induce cultural change. The media publicise our environmental problems because

sensationalism sells and maybe because of a trace of social responsibility. Educators teach about them because it is the right thing to do.

The challenge is to get sustainability happening in mainstream construction as that is where change will have the greatest impact. Purchasers are now aware that more sustainable buildings save heating and cooling costs and insulation is the norm. Multistorey buildings with a fraction of the lifetime energy costs are now routinely being constructed in many countries because they sell better. In time the materials buildings are made of will also change with more sustainable outcomes.

Paradigm Shifts in Technology

Small improvements in the technical deliverance of more sustainable products, materials and processes are important but it is the paradigm shifts in technology that will deliver results.

In the past improvements in technology brought us health and living standards that resulted in the explosion in population that has taken place in the last century. Along with increases in population and living standards came pollution at ever increasing levels. Fresh water is rare in some countries and even the air we breathe is often contaminated with the fallout from human activities. Technology brought us acid rain, pollution and the greenhouse gas problem and some scientists such as myself now believe that only technology can extricate us from it.

“The recognition, throughout the European Union and indeed the rest of the world, that sustainable growth should be a controlling process for guiding the development of technology through the millennium and beyond, is now well established.

The more difficult problem is defining the content and thrust of the effort necessary to convert the recognition into practice and then demonstrating, through the best practice, the techniques and technology appropriate to reinforce the value of sustainability. The value can and should be measured by both environmental as well as financial gains and there is no more logical start point than Targeted Research Action on Waste Minimisation and Recycling (TRAWMAR) (Miro, 2002).”

Given the scale of the problem improvements in current technologies will not be enough. Paradigm shifts in technologies that redefine materials, hence the resources and molecular flows that underlay their movement through the economy are essential. “By enabling us to make productive use of particular raw materials, technology determines what constitutes a physical resource”(Pilzer, P. Z., 1990).

The technological base of world economies will have to change strongly towards sustainability for there to be a significant reduction in anthropogenic global greenhouse gas emissions, wastes and the other environmental problems.

New materials with low embodied energies and emissions that deliver more than just strength or durability are urgently required. Many of these will be composites combining properties previously considered mutually exclusive such as thermal capacity and insulating ability.

To survive as a species we must find ways of sustainably creating the urban environment. According to Dr Joe Herbertson (Herbertson, J., 2004), "Taking a fundamental, systems approach is the key to major innovation; moving beyond current best practice to sustainable solutions"

I systematically worked on the problem of emissions and waste utilization in concretes and that is how I developed TecEco tec and eco-cements and a kiln technology that captures CO₂, combines grinding and calcining and uses solar or solar derived power for efficiency. I saw the big picture long before I worked out the detail.

The TecEco kiln tec and eco-cement technologies are examples of benchmark paradigm shifts in technology. They demonstrate that it is possible to think laterally and deliver technologies that are more sustainable in the context of our greater understanding of Earth systems.

Robotics as a Driver

Challenging the traditional construction paradigm and driven by potentially lower costs is robotics. In the USA and elsewhere in the world researchers are looking at using robots to literally print buildings. It is all quite simple from a software, computer hardware and mechanical engineering point of view. The problem is in developing new construction materials with the right flow characteristics¹² so they can be squeezed out like toothpaste, yet retain their shape until hardened.

Once new materials suitable for the way robots work have been developed economics will drive their acceptance for construction. The one material fits all purposes approach will increasingly have only limited relevance. Concretes for example will need to evolve from being just a high strength grey material, to a smorgasbord of composites that can be squeezed out of a variety of nozzles for use by a robotic workforce for the varying requirements of a structure.

¹² Bingham plastic rheology

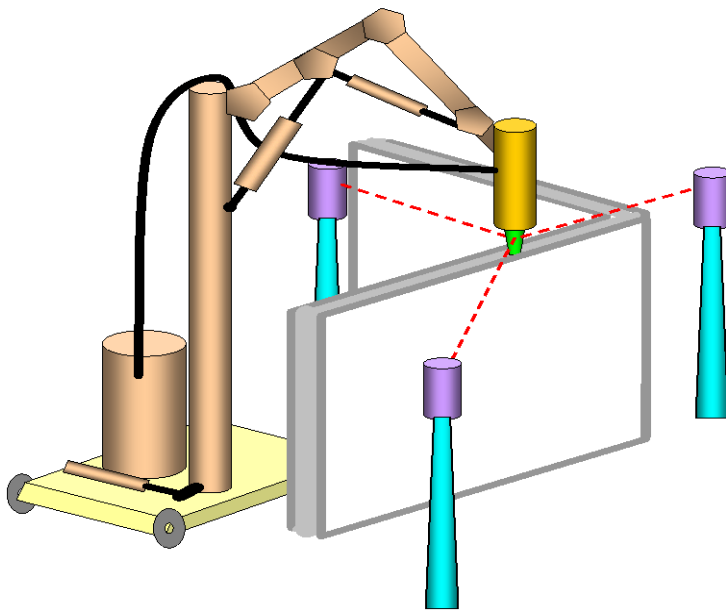

Figure 22 - Robotic Construction of Cementitious Composite Walling

Various materials from structural containing fibres for reinforcement to void filling and insulating will be required and like a colour inkjet printer will be selected as specified by the design.

Accuracy will be far greater than currently possible, wonderful architectural shapes as yet unthought of will be used and fibres will provide reinforcing. Walls will most likely have a low strength foamed insulating cementitious material between the faces making services easy to add at a later time. Conduits could also be provided by design.

The use of robots in construction will reduce the waste of new construction materials immensely. Just like an inkjet printer only uses the right amount of ink, only the exact amount of material will be used. The introduction of robots to construction will also mean more wastes can be utilised for building materials. More self hardening materials will be required, not less, and mineral binders like TecEco's new cements that have the right flow characteristics and obvious advantage of being able to utilise a large quantity of wastes (See The "Killer" Application – TecEco Cements on page 48) will find favour.

The Process of Change

Four important threads are discussed

1. Reducing, Re-using, Recycling and Recovery
2. Re-engineering the materials we use
3. Changing the molecular flows using non fossil fuel energy
4. Realising that Sustainability is Good Business Sense

Consider the techno-process. It has an input and output rate and volume dimension. It also involves the flow of matter. Everything between the take and waste is a material of one sort or another

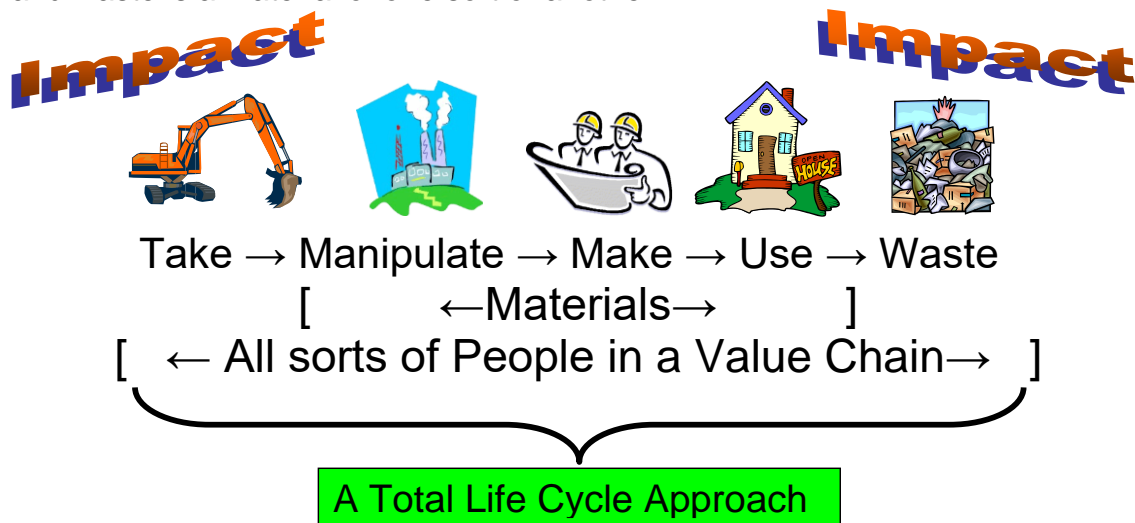

Figure 23 - A Total Life Cycle Approach to Materials

The take and waste of the techno-process both have impacts and linkages to the wider geosphere-biosphere. Most noticeable are at the macro level. Most dangerous may well be at the molecular level. We are producing too much CO₂, too many mobile heavy metals, too many compounds containing halogen carbon double bonds and so on.

The techno-process is uniquely driven by human behaviour. All sorts of people are involved in a value chain and each and every one of them is thinking about earning a living so the solution must also be economic (See The Economics of Change Towards Sustainability on page 38) otherwise it just won't happen.

The techno-process globally is huge and diverse. There is therefore no simple solution. Because it is so pervasive and diverse problems associated with it must be tackled in every way possible.

One set of approaches is to step by step change the techno-process until it becomes a climax industrial ecology characterised by:

- Using more renewable and less non-renewable resources.
- Slowing down the rate of the process.
- Slowing down the volume of through the process (de-materialisation as argued by factors 4-10 and the Natural Step)
- Integrating the process beyond the enterprise level (implying much more recycling).
- Reusing and remanufacturing

- Only wasting what is biodegradable or can be reabsorbed by natural processes.

These changes are embraced by the popular catchwords of Reducing, Re-using, Recycling and Recovering (See 1. Reducing the Impact of the Techno-Process on page 44.)

Another way that is connected to the other two ways is to change the materials we use. Materials are everything between the take and waste. Fundamentally changing what materials are composed of and how they are made will change what we take and what we waste. Changing the take and waste will change the molecular flows that underlie the techno-process that are of concern such as the production of CO₂ and other greenhouse gases. The idea that we can solve the problem by re-engineering materials is a major theme of this document. See 2. Materials In the Built Environment—The Key to Sustainability on page 49.

A third way is to reduce the impact of the molecular flows (too many CFC's too much CO₂, heavy metals in the global commons etc.) underlying the flow of materials through the techno process by reversing them using processes driven by free and abundant solar or solar derived energy rather than fossil fuels.

The TecEco process for saving the planet involves such a bold step and because it is economic has a good chance of success. (See 3. Putting a Process Together on a Huge Scale to Save the Planet on page 56)

The solution is thus a multi-dimensional and holistic re-tuning of the techno-process. The main weight of our footprint on the planet is in cities. Cities therefore offer huge opportunities for this process.

Industrial ecology, implying integration across enterprises so that the waste output of one kind of activity can be resource input for another, is most easily achieved in cities. "Cities make possible the treatment of industrial wastes because of the economies of scale and the agglomeration economies of having many similar industries together." (Gismondi, M. and Rees, W. E., 2004). It follows that sustainability is good business sense (See The Economics of Change Towards Sustainability on page 38.)

TecEco, my company, has uniquely proposed building cities of carbonate based eco-cement concretes as a way of sequestering massive amounts of carbon and using a wide range of wastes for their physical properties. More information on the exciting new development is available from the web site at www.tececo.com.

1. Reducing the Impact of the Techno-Process

It is essential that the human race, with all the power it has over the environment moves rapidly to reduce the impact of the techno-sphere on the geosphere-biosphere before it is too late. This will not happen because it is the right thing to do.

William McDonough and Michael Braungart in an approach inspired by design and nature make the case that an industrial system that "takes, makes and wastes" can become a creator of goods and services that generate ecological as well as social and economic value (McDonough, W. and Braungart, M., 2002).

In this paper it is argued that the impact of the techno-process can be reduced by introducing paradigm shifts in technology, particularly those relating to materials. It is important that these technologies are also fundamentally economic otherwise they are inefficient and not viable in the long run.

Economic viability attracts investment, and insufficient investment has in the past found its way into sustainability. Natural capital is undervalued.

Consider the techno-process:

Take → Manipulate → Make → Use → Waste

It has an input and output rate and volume dimension.

If the impacts of the techno-process on the geosphere-biosphere are to be reduced then the rate and volume of flows through the process need to be reduced.

A large proportion of what passes through the techno-process resides in it as the materials with which we build our techno-world (the techno-sphere). The rate and volume of the flow to produce or waste these materials can be reduced by:

- Reusing the materials even if in a different form
- Reducing the input to produce the same use or "utility" of the materials
- Recycling so that fewer resources are required to be extracted.

By reducing, re-using and recycling the process becomes:

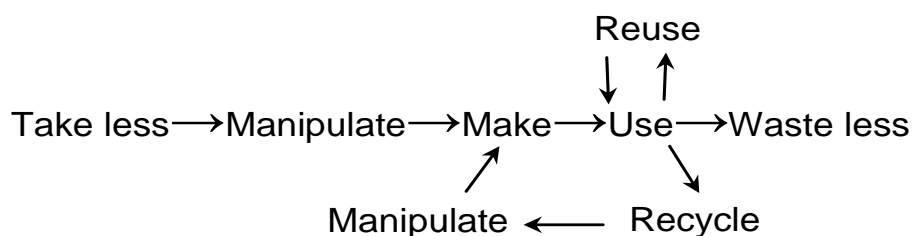

And more desirably:

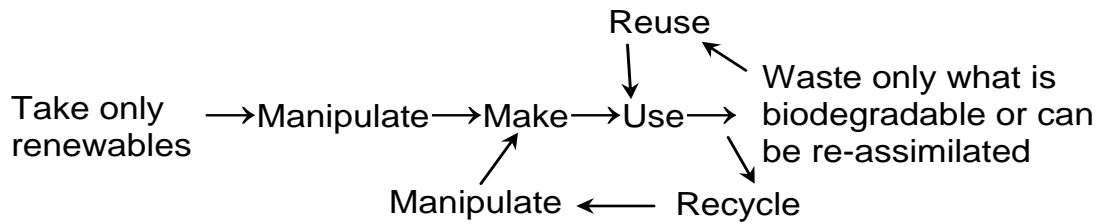

Reducing the “Take” & “Waste”

Before re-using and recycling can become economic the main economic hurdles to overcome are the laws of supply and demand and economies of scale. To do this we need to change the technical paradigm.

Henry Ford leveraged his success selling cars to devise more efficient methods of production. As a consequence he was able to sell his cars more cheaply, increasing sales, providing more money for innovation, which reduced costs even further and so on. Ford was able to sell more at lower prices and yet make more money by achieving economies of scale. The laws of economics rely on positive feedback loops. Industrial economies of scale tend to increase value linearly, while the laws of supply and demand would dictate that exponentially more is sold or used the lower the price for the same quality.

It can however take years before these laws kick in.

For example during the first 10 years, Microsoft's profits were negligible. They started to rise in 1985 and then exploded. The experience of Federal Express was similar. The same applies to fax machines and the internet which similarly languished for some time before becoming ubiquitous.

The question is whether the world can wait for an explosion in the recycling business to take place. There is a desperate need to achieve sustainability quickly. What factor or factors are missing? What will make it happen as a matter of profitable economics rather than policy?

The trouble is that right now it just costs too much to reuse and recycle for these processes to be driven by economics alone. As a consequence government intervention in the form of regulation (Germany, some other countries and some states in some countries e.g. South Australia in Australia to some extent) and subsidies (most of the rest of the developed world) are required for what is a desirable social outcome.

How can re-using and recycling move beyond the desirable, subsidized by tax dollars to being supported by the push and drag of sound economics?

The problem is that in many cases it is more expensive to reuse and recycle than to use newly extracted resources. There would be a rapid turnaround in the sustainability industry if this hurdle could be overcome so that it was cheaper to reuse or recycle.

There are two main costs involved in re-using and recycling. The costs of sorting waste streams and transporting sorted recyclable materials back to a location in which they can be reused.

The second law of thermodynamics (the law of entropy) was formulated in the middle of the last century by Clausius and Thomson. Like most natural processes, waste streams tend to follow this law in that wastes at the point of elimination from the techno-process tend to be all mixed up. Disorder is prevalent for two main reasons; things are made with mixed materials and the waste collection process tends to mix them up even more.

Current technical paradigms underlying the techno-process generally require separate inputs. Costs are incurred and waste generated in separating what is required from the balance of material as nature itself rarely concentrates. As mentioned earlier, one study found that around 93 percent of materials used in production do not end up in saleable products but in waste (Von Weizsäcker, E. U., Lovins, A. B. et al., 1997).

Re-using and recycling is even more uneconomic because the cost of un-mixing increasingly complex waste streams is prohibitive. After recycling is completed there is the cost of returning the materials back to manufacturers who can use them. Simultaneously dealing with the disassembly/sorting constraints, scale cost, material problems and transport issues during recycling are critical cost challenges.

I once had the pleasure of a discussion with Edward de Bono, the inventor of the words “lateral thinking” about the TecEco cements I invented. He said that what was needed for market success was a “killer” application, an application that just could not help but succeed.

To get over the law of economies of scale and to make the sorting of wastes economic so that they can be used as low cost inputs for the techno-process new technical paradigms are required. These new paradigms involve redefining the way materials are made, used and recycled:

- Including intelligence in materials
- A “killer” application for unsorted wastes
- Adding value to wastes by redefining them as inputs to new materials.

Applying the intelligence of Computers to the Problem

Others have realized the economies of reusing the output of one process or enterprise in another before they become further mixed up at the tip face. By applying modern intelligent data management techniques databases are being maintained that match wastes from one process or enterprise with the needs of another. This type of industrial integration of “ecology” is to be encouraged. But what if we could take the concept a lot further? What if we could get over the identification problem and confound the law of entropy at the tip face?

The means to very efficiently sort wastes may just lie in the silicon chip. The cost and size of silicon with embedded memory and intelligence are both falling exponentially. Silicon chips already have a diverse range of uses. For example they are being used in paint by car manufacturers for identification purposes and one was recently put in the ear of my dog for the same reason. Silicon chips will one day be as plentiful as what they could be embedded in. They will tell us the cost at the check-out, the manufacturer, warranty details who the owner is and what waste stream a robot should put them into when eventually wasted.

The only economic hurdle that would remain would be the efficient transportation back to manufacturing points of these waste streams.

The “Killer” Application – TecEco Cements

The intelligent sorting of materials gets over the entropy law problem but transport is still an issue. What if wastes could be utilized depending on their class of physical properties rather than their chemistry as aggregates or fillers for concretes. Concretes are used everywhere, over two tonnes per person on the planet per annum was the figure mentioned earlier. Utilized in vast volumes waste materials that offered useful broadly defined physical properties such as light weight, tensile strength, insulating capacity, strength or thermal capacity would add value to composites.

There are many wastes that are just too costly to further sort into specific wastes streams such as many plastics. There are also waste streams such as mine tailings, furnace sands, quarry dusts and the like for which no particular use could otherwise be found.

Glasses tend to share in common many properties as do plastics, wood, ceramics and so on. Glasses are brittle, tough and abrasion resistant. Plastics are generally light, insulating and have tensile strength. What if it did not matter if glasses were mixed up with glasses and plastics with other plastics?

The solution is to use these materials in composites for their physical properties rather than for their chemical composition. The problem then becomes one of finding a potentially cheap, un-reactive but strong binder with the right rheology for use by for example robots of the future. See Reducing the “Take” & “Waste” on page 46.

Plastics, epoxies and other inorganic binders are just too expensive. The choice for durability and cost is a mineral binder. Ordinary Portland cement concretes are not suitable because they are too reactive to use with a wide range of wastes as aggregates or fillers. The breakthrough has been the development of a wide range of blended calcium-magnesium binders developed by TecEco with a low long term pH that are internally much drier and that therefore do not react with wastes.

TecEco technologies also offer significant abatement or in the case of eco-cements, sequestration. A major advantage of the TecEco technology over all

other sequestration and abatement proposals is that the technology itself is viable even without a value being placed on abatement and sequestration.

The TecEco technology is but one very important example of where redefining materials can make a big difference to sustainability by for example providing composites that utilise wastes. There are other ways improvements in materials will make a big difference.

Adding value to wastes by redefining them as inputs to new materials.

Gold is a very “heavy” and potentially toxic metal. Ever heard of it going to landfill? Gold is not wasted because it has too high a value.

By underpinning the value for carbon artificially created by the Kyoto treaty with a real value we can solve the problem of global warming and climate change as, driven by economics, people will invent all sorts of ways to capture the gas out of the air.

It is the same with other wastes that are detrimental to the environment – we need to find ways of incorporating them as re-inputs to materials in the techno-process thereby adding value.

2. Materials In the Built Environment–The Key to Sustainability

In the last few years tremendous progress has been made improving the lifetime energy performance of buildings and the architects and engineers who have led the way are to be applauded for suggesting that many products can be used, recycled, and used again without losing any material quality - in cradle-to-cradle cycles (McDonough, W. and Braungart, M., 2002).

Fundamental changes are necessary to materials if we are to achieve real improvements in the value/impact ratio loosely referred to as “sustainability”.

The way forward will be utilising new technical paradigms defined by innovative new materials such as TecEco tec and eco-cements and geopolymers.

Materials are the lasting substances that flow through the techno-process. They are the link between the geosphere-biosphere and techno-sphere and hence everything between and defining the take and waste.

To reduce the impact of the techno-process that describes the flow of these materials from take to waste, it is fundamental that we think about the materials we use to construct our built environment and the molecules they are made of.

With the right materials technology, because of its sheer size the built environment could reduce the take from the geosphere-biosphere and utilise many different wastes including carbon dioxide.

Materials used to construct the built environment should, as well as the required properties have low embodied energies, low lifetime energies, and low greenhouse gas emissions when considered on a whole of life cycle basis. They should also preferably be made from renewable resources and easily be recycled or reassimilated by the geosphere-biosphere.

The choice of materials in construction has a huge impact on many value properties including weight, embodied energies, fuel related and chemical emissions, lifetime energies, user comfort and health, use of recycled wastes, durability, recyclability and the properties of wastes returned to the geosphere-biosphere.

Fundamental changes are necessary to achieve real sustainability and if these are to occur without economic disruption, as the materials we use control the sustainability of the systems we proliferate, the materials paradigm we live in will also have to change.

Given the enormous materials flows involved, the obvious place to improve sustainability is the built environment. The materials used determine net emissions, the impact of extraction, how they can be reused and the effects of wastage on earth systems.

For the construction industry to progress much further the impact of the techno-process on the environment must be reduced and materials that are more sustainably made and that deliver greater sustainability in use are required.

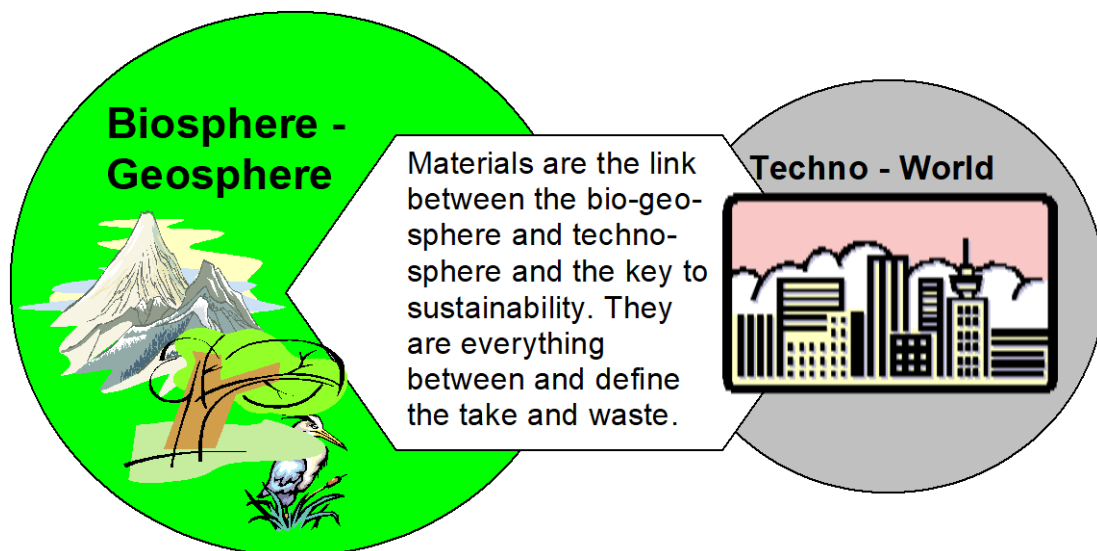

Figure 24 - Materials - The Key to Sustainability and Link between the geosphere-biosphere and Techno-world

Materials science will increase in importance as the race to develop materials for the future gets underway. Many materials need a serious makeover or reinventing!

Consider some of the ways in which this could occur.

Weight

- Lighter materials mean lighter buildings which in turn means less materials and lower embodied energies and construction costs.

For example materials that are light in weight are not generally strong. It should be technically possible to combine these properties without increasing costs or embodied energies as for example with eco-cement formulations for sawdust bricks.

Embodied Energies & Emissions

Materials have embodied process energy and emissions and in the case of calcined materials associated chemical emissions.

Without considering chemical releases the amount of carbon dioxide emitted is directly proportional to the energy used during manufacture (the embodied process energy). This is because over 95% of the world's power is generated from fossil fuels.

The embodied process energy per unit mass of materials used in buildings (and hence CO₂ emitted) varies enormously from about two gigajoules per tonne for concrete to hundreds of gigajoules per tonne for aluminium.

Because some materials such as concrete have associated chemical releases of carbon dioxide, the differing properties of materials, differing quantities required to perform the same task and different design requirements, using these values alone to determine preferred materials to reduce emissions is inappropriate.

- A reduction in process energy during manufacture implies greater economic efficiency. Ways of making existing materials or new materials with the same or better functionality and properties but with lower embodied energies are therefore more cost affective.

Examples include the new TecEco tec-kiln which combines calcining and grinding and can be heated using solar, wind or waste energy. As a consequence the manufacture of TecEco cements involves much less process energy. Furthermore grinding is only 1-2% efficient and most of the energy required ends up as heat reducing energy required for calcining by around 30%.

Materials such as concrete and timber having lower embodied energy intensities and hence emissions per tonne are used for construction in very

large quantities; whereas the materials with high energy content and emissions such as stainless steel and aluminium are used in lesser quantities.

The average suburban house would contain in the order of 600 – 1000 Gigajoules of embodied energy. The most used material is concrete followed by ceramics (brick). Because such huge quantities are used however, by far the most embodied energy (and hence emissions) for the average building is from concrete. Masonry and ceramics (together as a group) follow. Because so much concrete is used in construction generally and because concrete also has associated chemical releases, the effect of using sustainably made tec and eco-cements instead of concrete, masonry and ceramics could cause the embodied energy in an average house in Australia to drop by more than 250 - 300 Gigajoules and emissions in the order of 15 – 18 tonnes CO₂

Geopolymers potentially also have very low embodied energies at least until all the fly ash in the world is utilised. Although the production of metakaolin or kandoxi involves process energies, they are generally only used in better quality geopolymers.

The best publicly understood example of embodied energies and emissions are those associated with the manufacture of ordinary Portland cement.

Lifetime Energies

The physical properties of materials such as thermal capacity, insulating ability and opacity have a substantial effect on lifetime energies. It is true to say that good design is to some extent based on best utilising the properties of the materials used.

- The properties of many materials are too focussed. It is possible to develop new materials with more than one property currently considered as conflicting.

For example materials that are good insulators do not generally have a high heat capacity. These properties are not necessarily mutually exclusive and combining insulating and heat capacity has huge potential for reducing the lifetime energies of buildings.

Heat Absorbing or Releasing Materials

Phase change materials are becoming available such as waxes or encapsulated glaubers salts that having very high heat capacity and therefore increase the heat capacity of the composites in which they are placed. Other materials such as some zeolites have a very high absorption energy for water and can work in a similar way.

Using these new materials and TecEco cement composites, materials with both high heat or cold capacity and insulating capability could be made.

Composites Made Using TecEco Cements as an Example of Materials with Superior Properties

Many wastes such as cellulose fiber from wood, plastics, straw, sugarcane bagasse, kenaf, hemp and guayule, have physical properties such as light weight and tensile strength that would make them suitable for use in composites with cheap mineral binders. One of the problems holding up the development of such composites has been the high alkalinity of Portland which causes weakness as a result of internal reaction. TecEco tec and eco-cements are nowhere near as alkaline and for this reason, and because they stick very well to other materials, they will be pivotal in the quest to utilize more wastes, converting them to resources.

User Comfort and Health.

Some materials are more comfortable to live with than others. Combined with good design they provide the right temperature, noise levels and other creature comforts required.

It is also essential that buildings are healthy to live in. Unfortunately many new materials such as modern varnishes, glues in plywoods and plastic finishes give off gases that not only smell but that are potentially carcinogenic or hormonal in action. Many traditional paints such as lime wash and those based on casein do not have this problem. Modern paints are now being reinvented to be more healthy.

Lime and Eco-cement concretes and mortars.

Carbonating concretes and mortars such as those based on lime or the new eco-cement require the material in which they are used to be able to “breathe” to carbonate properly. Allowing walls to breathe makes buildings healthier to live in.

Ever walked up rocks on a beach on a hot day? The materials we use have a strong influence on our comfort levels on a wider scale. Recently in Tokyo and other large cities with badly designed concrete, “hot island phenomena,” whereby the city itself is several degrees warmer than surrounding areas has become a major issue.

The Use of Recycled Wastes

Supplementary cementitious materials like fly ash and ground vitrified blast furnace slag are increasingly being used in concrete. The use of other recycled wastes for their physical properties is lagging.

- The use of supplementary cementitious materials reduces the need for concrete and is therefore more sustainable.

The Use of Geopolymers and TecEco Cements to Utilize Wastes

Geopolymers are very simply described as low temperature silica-alumina glasses in which, instead of heat, alkalis are used to break down silicates that incorporate metallic cations when they reform. They are most suitable for use with wastes that contain silica and alumina and provide a high temperature

stable environment for encapsulation of problem elements such as heavy metals.

TecEco tec-cements have many of the properties of geopolymers. TecEco cements generally are suitable to incorporate wastes mainly because they are chemically benign and because they stick so well to other materials. They are described by:

- Lower reactivity (less water, lower pH)
- Reduced solubility of heavy metals (lower pH)
- Greater durability
- Increased density and impermeability
- Increased homogeneity
- No bleed water
- Less attack by salts in ground or sea water, and
- Increased dimensional stability with less cracking

Getting Over the Problem of Carcinogens, Heavy Metals etc.

The use of cementitious binders to bind all sorts of wastes to make composites for constructing the built environment makes sense.

The public must however be assured there is no risk of coming into contact with heavy metals.

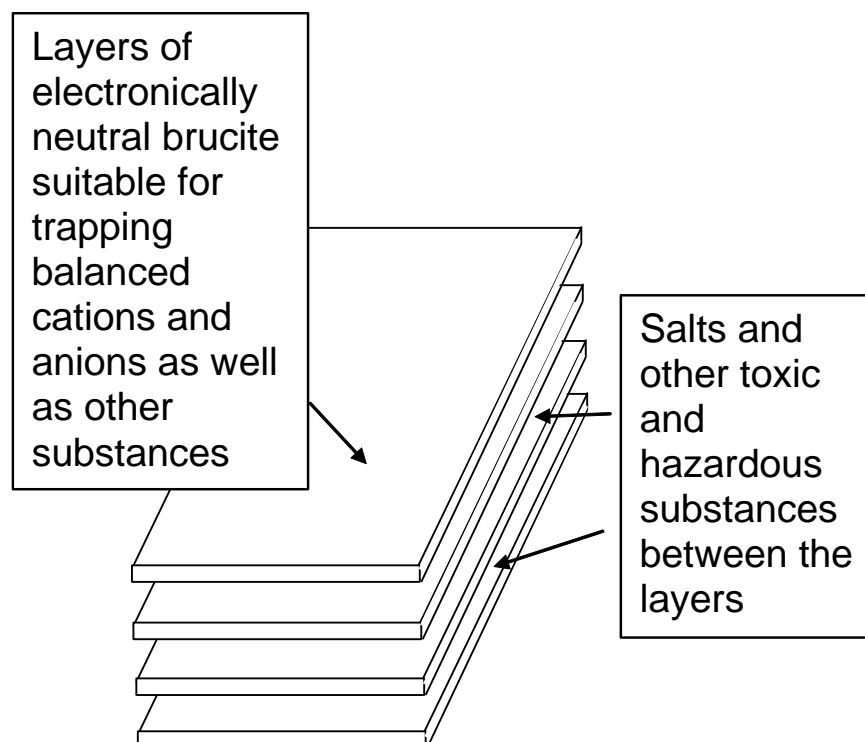

Figure 25 -Structure of Brucite

In a TecEco tec-cement Portland cement brucite matrix:

- OPC takes up lead, some zinc and germanium

- Brucite and hydrotalcite are both excellent hosts for toxic and hazardous wastes.
- Heavy metals not taken up in the structure of Portland cement minerals or trapped within the brucite layers end up as hydroxides with minimal solubility.

Brucite, one of the main minerals formed in TecEco tec-cements has an ideal structure for capturing balanced cation anion pairs and has an equilibrium pH at a suitable lower level to minimize the solubility of heavy metals.

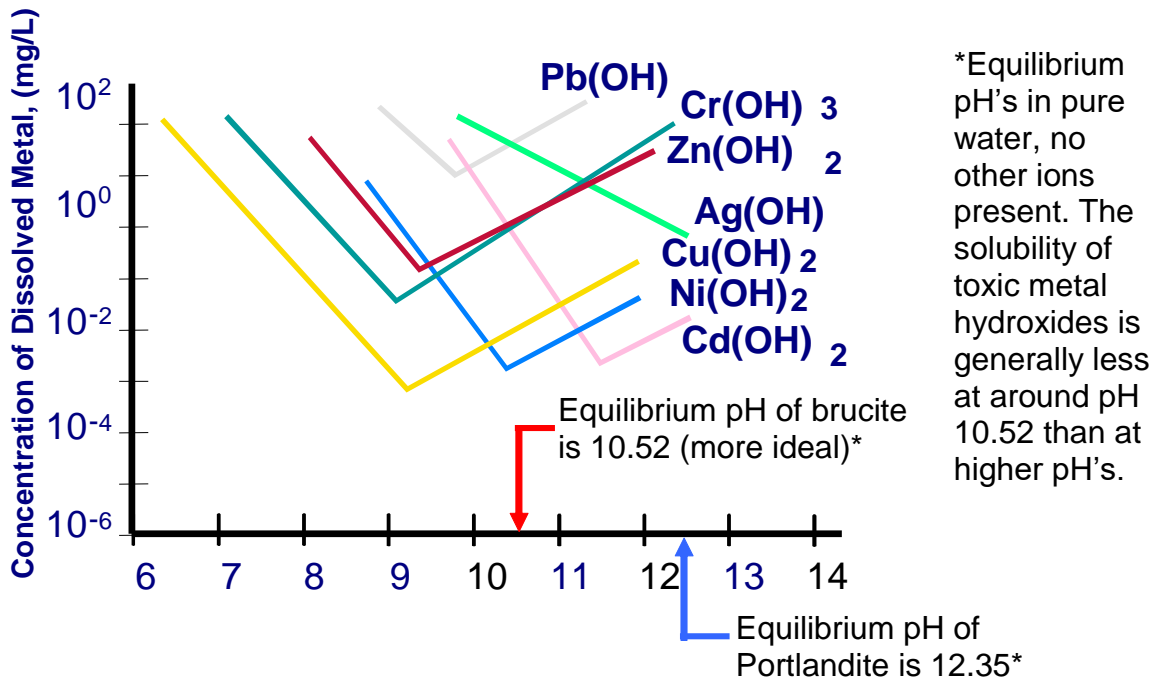

Figure 26 - pH Conditions in TecEco Cements

Durability

- Materials that remain useful for longer are required.

The time is past when the likes of Henry Ford could reduce the quality of materials and components made from them deliberately to sell more vehicles more often. The less often materials or things from them are made the less energy consumed and lower emissions and other detrimental outcomes.

Imagine if functionality and service were purchased instead of energy and things. This was a theme in the book "Natural Capitalism" and an example given was that instead of buying electricity one would purchase heating and lighting (Hawken, P., Lovins, A. et al., 2000).

I recently had the pleasure of entertaining in Tasmania the representative of a Brazilian company, Magnesita S.A. He told me that his company no longer just sold refractory bricks. They were paid on the basis of downtime experienced by their steel producing clients. With better quality bricks and less downtime they were paid more.

Durable Concretes

Geopolymers and TecEco cements are much more durable mainly because the minerals in them are thermodynamically very stable or less soluble.

Recyclability

- Materials and the things that they are used to make should be engineered with their next use in mind so that they never exit the techno-process and become waste.

An example already used in the construction of the built environment is modular formwork.

The properties of wastes returned to the geosphere-biosphere.

- Materials will be required that are either biodegradable or easily recycled within the techno-sphere.

An example of materials that are currently not recycled that could be would be bricks and blocks bonded together using softer carbonating eco-cement or lime mortars which would be easier to clean and thus recycle as they were in the past.

3. Putting a Process Together on a Huge Scale to Save the Planet

Concrete is the biggest material flow on the planet¹³ and therefore offers significant opportunities for improvements in sustainability.

Comparative Sustainability of Various Binders

Other than eco-cements and carbonating lime mortars that carbonate and therefore have a clear advantage and tec-cements that perform well because less is used, there are a number of other novel cements with intrinsically lower energy requirements and CO₂ emissions than conventional Portland cements that have been developed including high belite (C₂S) and calcium sulfoaluminate (C₄A₃S) types as shown in Table 1 below.

From Table 1 it can be seen that uniquely carbonating lime mortars and TecEco eco-cements are by far the most sustainable in terms of CO₂ and can even be net carbon sinks. Using a building material that is CO₂ neutral or even sequesters carbon makes a lot of sense - after all that is what nature has been doing for the past 3 – 7 billion years depending on your opinion as to the age of the earth. Utilising wastes also make sense. The potential for keeping the planet the way we can survive on it is enormous.

¹³ Previously mentioned at over two tonnes per person on the planet per annum.

Table 1 - CO₂ Released by De-Carbonation during the Manufacture of Cements and Components ¹⁴

Compound	CO₂ released through decarbonation in producing 1 tonne (tonnes CO₂/tonne Compound)	CO₂ potentially recaptured in a porous concrete or mortar—tonnes CO₂ per tonne Compound	Net Emissions (if no capture—tonnes CO₂ per tonne Compound)	Net Emissions (if capture for MgO and CaO only –tonnes CO₂ per tonne Compound)	Example of Cement Type
MgO	1.09	1.09	0	-1.09 (net sequestration)	Eco-cement mortar
CaO	0.78	0.78	0	-.78 (net sequestration)	Carbonating lime mortar
C ₃ S	0.578	.289	.289	Not feasible technically yet	Alite cement
C ₂ S	0.511	.255	.256	Not feasible technically yet	Belite cement
C ₃ A	0.594	0	0.594	Not feasible technically yet	Tri calcium aluminate cement
PC	0.54	.27 (variable)	.27	Not feasible technically yet	Portland Cement
1PC:2MgO	0.99	.817	.173	-.817 (net sequestration)	Eco-cement with no pfa
1PC:2MgO:3pfa ¹⁵	0.445	.367	.077	-.367 (net sequestration)	Eco-cement with pfa
1PC:2pfa ¹⁵	.27	.137	.137	Only feasible for the MgO	Very high fly ash

¹⁴ Geopolymers are unique and are not included in the above table because they fall into the class of chemical cements.

¹⁵ Assuming no emissions for pfa or that they are accounted for in the power industry.

				component	cement
.05MgO: 95PC:2pf a	.18	.092	.092	Only feasible for the MgO component	Tec- cement assuming 1/3 (.334%) less binder required.
C ₄ A ₃ S	0.216	0	.216	Not feasible technically yet	Calcium sulfoalum inate cement

Eco-Cement, The Magnesium Thermodynamic Cycle and Sustainability

Because of the high efficiency of CO₂ capture by magnesium oxide and for a number of other technical reasons TecEco propose the partial substitution of Portland cement with magnesia (MgO) which in eco-cements in porous materials fully carbonates

MgCO₃ → MgO + ↓CO₂ - Efficient low temperature calcination & capture

MgO + ↓CO₂ + H₂O → MgCO₃.3H₂O - Sequestration as building material

Understanding the magnesium thermodynamic cycle depicted below is very important in relation to understanding the massive potential of eco-cements for sustainability.

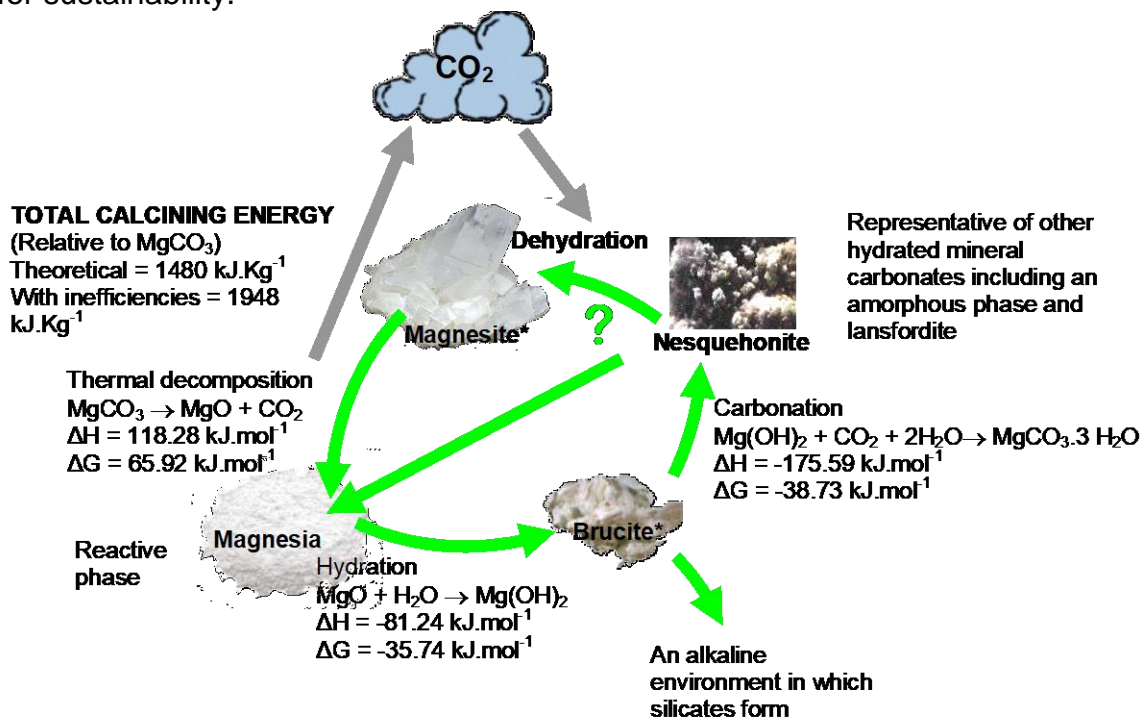

Figure 27 - The Magnesium Thermodynamic Cycle

There are several important features of this cycle; it is a cycle and relatively speaking it does not take much energy to make it go around and around. Better still this can be done at relatively low temperatures. Calcining can therefore be carried out in a closed system and the CO₂ captured.

Grinding and calcining at the same time produces more uniform product, allows the capture of CO₂ and utilises waste heat from grinding ¹⁶.



Eco-cements in a relatively porous matrix such as a concrete block, porous road pavement or mortar, complete the cycle gaining strength by carbonating, the CO₂ required coming out of the surrounding air.

The implications of using TecEco cements in the context of mineral sequestration to solve the problem of global warming are discussed below under the heading Sequestration on a Massive Scale.

Figure 28 - The World's First Eco-Cement Porous Pavement, Windsor Park, Glenorchy, Tasmania

There are other sustainability advantages as well:

- Magnesium has a strong affinity for water in solution and does not lose it readily during carbonation. The result is that solid hydrated carbonates like nesquehonite are formed that are 83 mass% water and CO₂! - Cheap sustainable binder!!!
- Magnesium carbonates are generally fibrous and acicular and therefore add microstructural strength.
- The long term pH is much lower than Portland cement concretes. Combined with the fact that magnesium minerals seem to stick well to other materials the result is that a high proportion of wastes can be included.
- TecEco cements are generally are much more durable. Materials that last longer are much more sustainable.

¹⁶ Around 98% of the energy that goes into grinding ends up as heat. Some 30% of the energy in a conventional cement plant goes into the grinding process.

Eco-Cement compared to Carbonating Lime Mortar.

The underlying chemistry is very similar however eco-cements are potentially superior to lime mortars because:

- The calcination phase of the magnesium thermodynamic cycle takes place at a much lower temperature
- Magnesium minerals are generally more fibrous and acicular than calcium minerals and hence a lot stronger.
- Water forms part of the binder minerals that forming making the cement component go further.
- Magnesium hydroxide in particular and to some extent the carbonates are less reactive and mobile and thus much more durable.
- A less reactive environment with a lower long term pH.
- Because magnesium has a low molecular weight, proportionally a much greater amount of CO₂ is captured.

The low molecular weight of magnesium results in a higher CO₂ content per tonne as in the calculations below.

$$\frac{CO_2}{MgCO_3} = \frac{44}{84} = 52\%$$

$$\frac{CO_2}{CaCO_3} = \frac{44}{101} = 43\%$$

Sequestration on a Massive Scale

Alkali metals like calcium and magnesium release a large amount of chemically bound CO₂ when their oxides are made from their carbonates. If this chemically released CO₂ could be captured during manufacture and reabsorbed during setting forming a strong binder, there would be huge opportunities for safe sequestration in the built environment with no possibility of leakage or detrimental affects on a wider scale.

The capture of CO₂ at source during the manufacturing process is easier for the calcination of magnesium carbonates than any other carbonate mainly because the process occurs at relatively low temperatures. TecEco Pty. Ltd. own intellectual property in relation to a new tec-kiln in which grinding and calcining¹⁷ can occur at the same time in the same vessel for higher efficiencies and easy capture of CO₂. Provided sufficient uses can be found for pure CO₂ produced during manufacture whereby it is also permanently

¹⁷ Calcining in the context of this document refers to the heating of limestone or magnesite to drive off CO₂ and produce the oxide.

sequestered, a system for sequestration on a massive scale using carbonates as building materials is very promising.

TecEco's proposed modification to the carbon cycle is shown in Figure 29 on page 61. Possibilities for alternative permanent disposal are in materials such as plastics or deep underground where CO₂ reacts with country rock forming more carbonate.

By utilising the new TecEco technologies and intelligent design, there is no reason why buildings could not be much more sustainable than current state of the art - not only with low embodied energies and emissions but low lifetime energies as well.

How TecEco want to change the carbon cycle is depicted in on page 61.

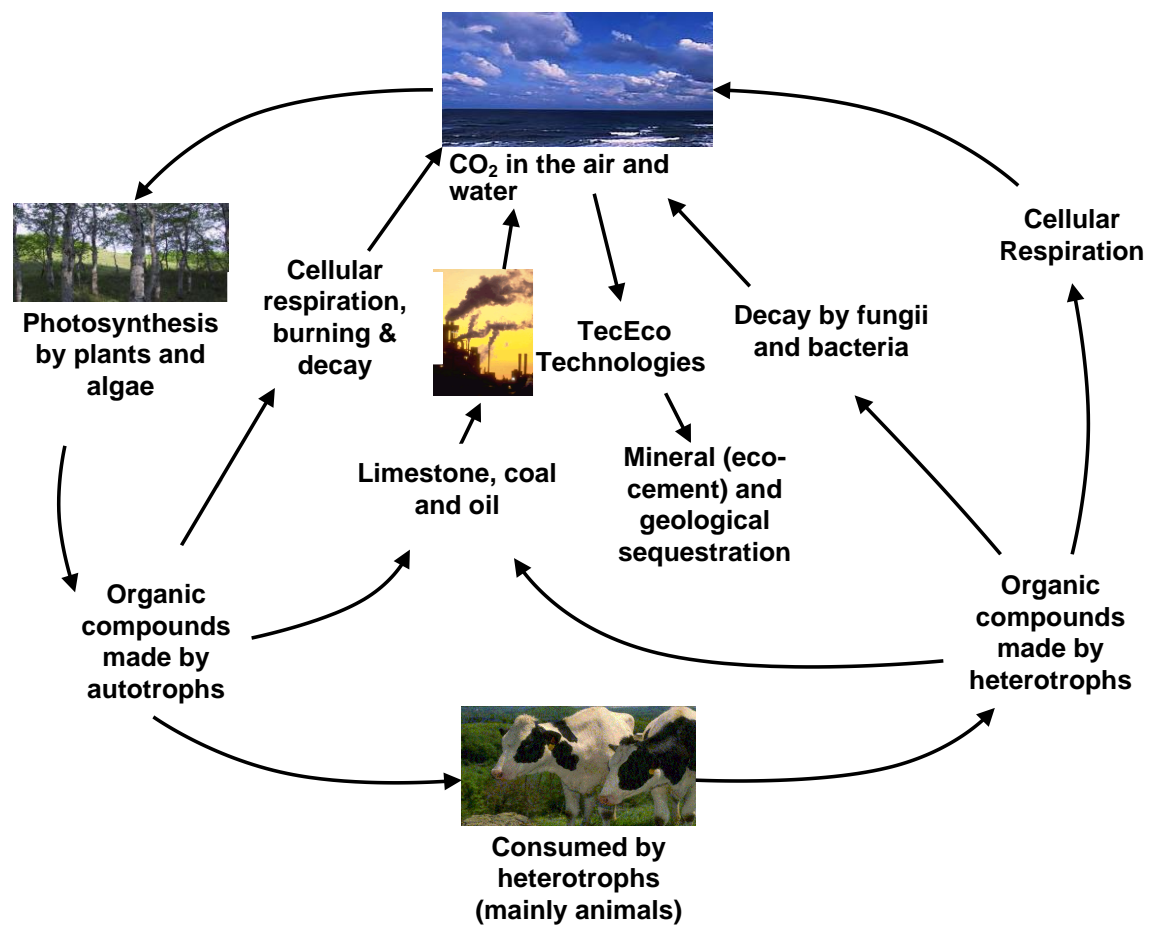

Figure 29 - The Carbon Cycle as TecEco Would Like to Modify It (Adapted from Kimball (Kimball, J. W., 2004))

Interfacing With Mineral Sequestration.

Using either forsterite or serpentine as inputs, the tec-kiln technology previously mentioned provides a method of calcining the magnesium carbonate produced using solar derived intermittent energy or waste energy from other sources. The magnesium oxide (MgO) produced can be used to

directly sequester more CO₂ in a scrubbing process or to sequester carbon as hydrated magnesium carbonates in the built environment.

Using tec-kiln technology magnesium fixes carbon dioxide and therefore acts as a concentrator. (Figure 27 - The Magnesium Thermodynamic Cycle on page 58 depicts to the technically minded how this is so).

A process diagram showing combined mineral and eco-cement sequestration is included as Figure 30 on page 63.

The idea of capturing CO₂ as carbonate in the built environment mimics what has in fact naturally been occurring for millions of years¹⁸. Carbonates formed in seawater are the natural, large scale, long term sink for carbon dioxide, however the process takes over 1000 years to equilibrate. Good evidence of the enormous volumes of CO₂ that have been released from the interior of the earth during many volcanic episodes over the last few billion years is the high percentage (7%) of the earths surface covered in rocks such as limestone, dolomite and magnesite.

¹⁸ There have been at least seven (7) other epochs of global warming easily discernable from the geological evidence.

The TecEco Total Process for Saving the Planet

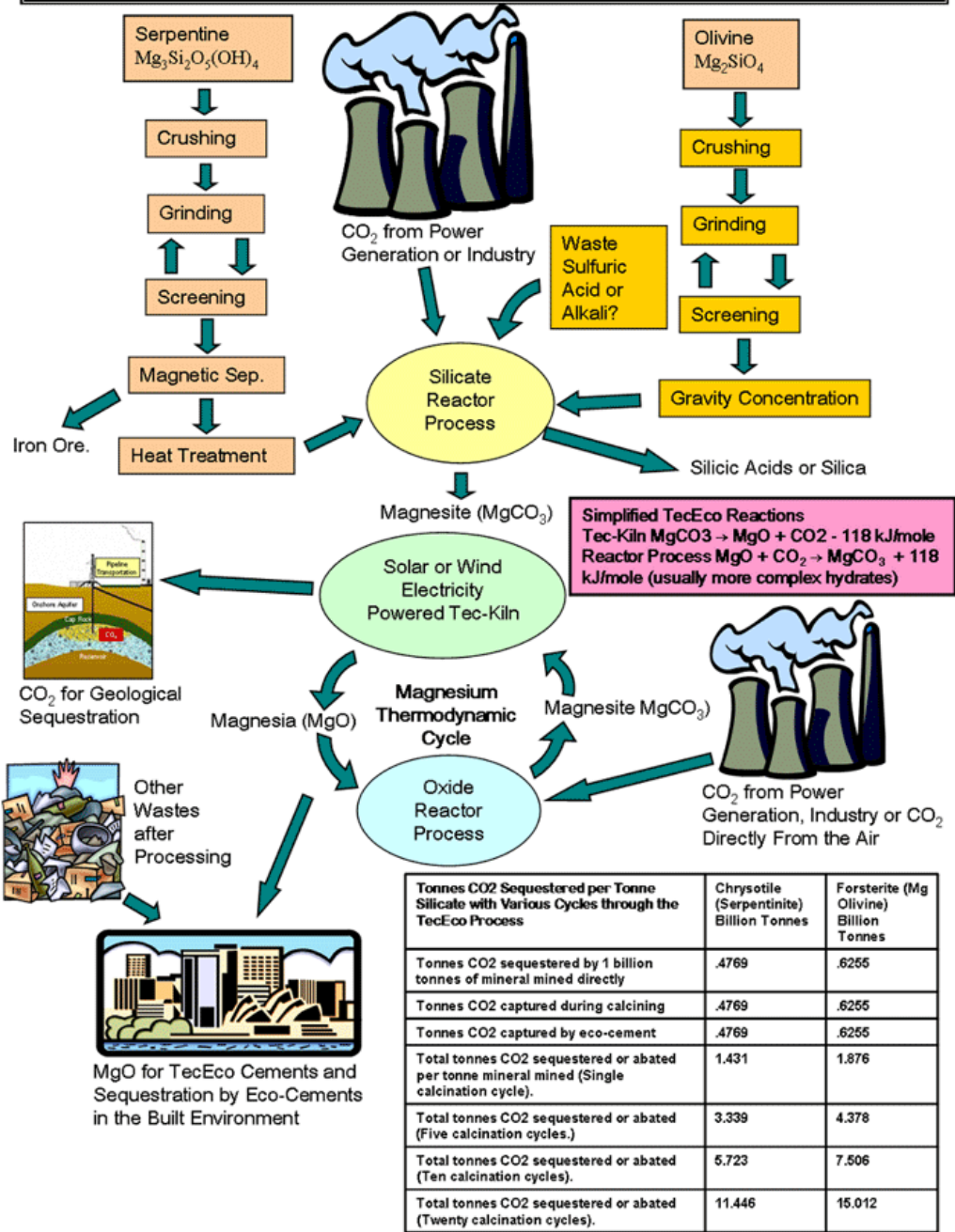

Figure 30 - The TecEco Process for Saving the Planet - How TecEco Technology Can Turn Global Warming around by Connecting Mineral and Geological Sequestration

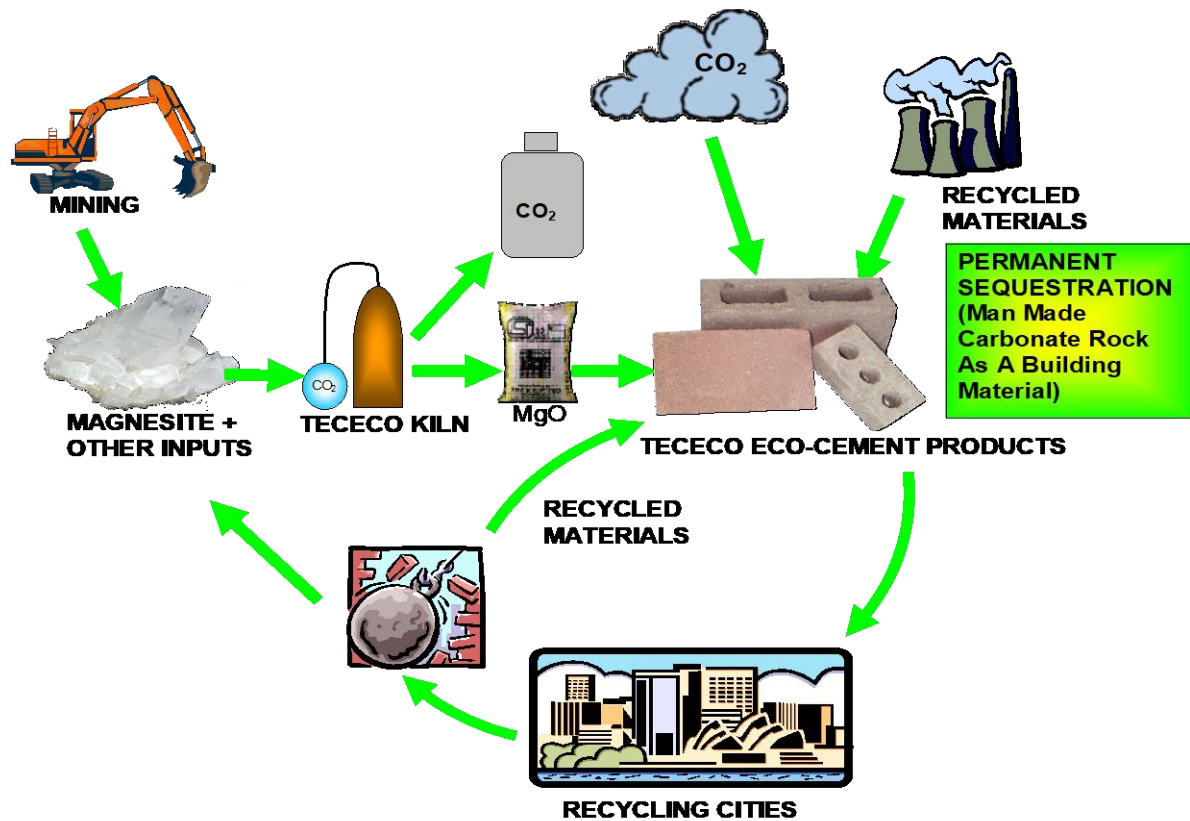

Figure 31 - TecEco Cements for Sustainable Cities

If carbon dioxide is captured during the calcining process for the manufacture of reactive magnesia then it can either be geologically sequestered or recaptured as eco-cements in porous cementitious materials for the built environment. Eco-cements gain strength with the formation of magnesium carbonates including lansfordite, nesquehonite and an amorphous phase mineral all of which because of their generally acicular shape add microstructural as well as innate strength as binders.

Oil has remained trapped in strata for millions of years and on this basis it is argued that carbon dioxide pumped down to push it up would also remain trapped. Given the fact that on average the pH of the earth is the same as that of seawater (8.2) then some neutralisation with the formation of immobile carbonates is also expected.

Kinetically the carbonation of eco-cements in the built environment will only proceed rapidly in porous materials such as bricks, block, pavers, mortars, porous pavement etc., which, fortunately, make up a large proportion of building materials. All these materials, including mortars, require the use of appropriately coarse aggregates for carbonation to occur efficiently. The effect of the substitution of Portland cement with MgO in a simple concrete brick formulation containing 15% cement with and without capture of CO₂ during manufacture of magnesia is depicted in

Figure 32 - Abatement in a Concrete Brick Containing 15% Eco-Cement below.

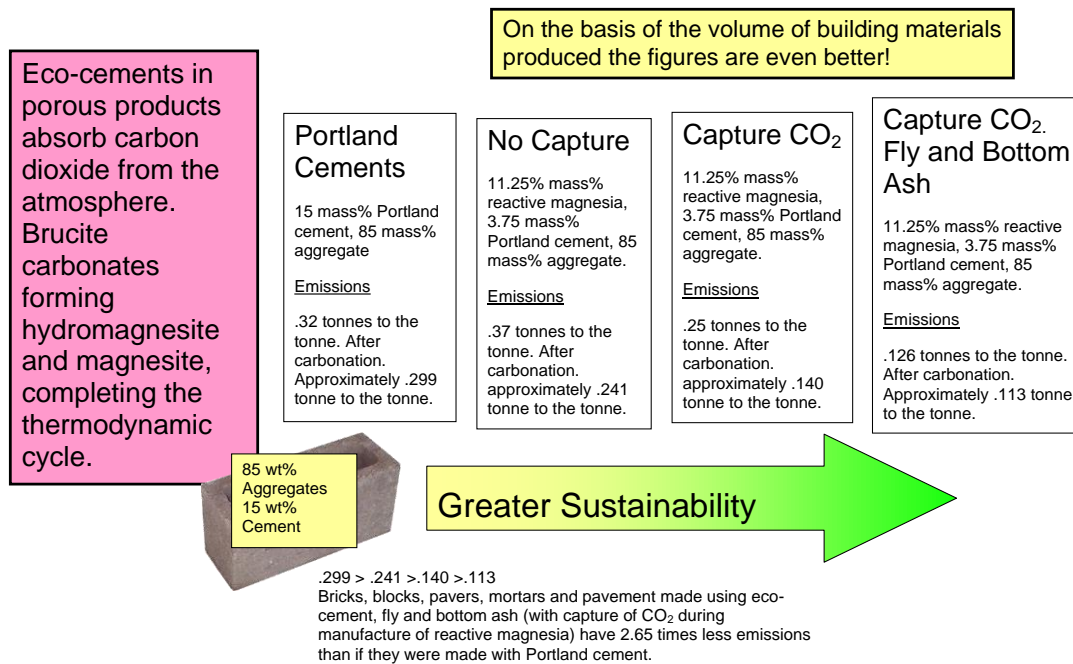

Figure 32 - Abatement in a Concrete Brick Containing 15% Eco-Cement

From Figure 31 it can be deduced that almost 2/3 of the CO₂ in concrete is potentially abated if substituted by eco-cement in porous products such as bricks, blocks, pavers, mortars etc. With CO₂ capture or the inclusion of organic fibre materials and fillers for strength and insulation, cementitious building materials that act as net carbon sinks are feasible.

Organic fibres may include wood fibre, straw, sugarcane bagasse, kenaf, hemp and guayule. Organic fillers could include much sawdust currently going to waste.

The above explanation is simplistic. As the energy considerations are complex readers are directed to the web site of TecEco at www.tececo.com where further papers are available.

What's Proven and What's Not

The deposition of carbonate sediments is a slow process and involves long periods of time. Ways of accelerating sequestration using carbonates include geological sequestration and mineral carbonation. Although promoted by the petroleum industry as a means of extracting remaining reserves of oil "there are significant fundamental research needs that must be addressed before geologic formations can be widely used for carbon sequestration.(NETL, 2004)" Mineral carbonation, the reaction of CO₂ with non-carbonated minerals to form stable, benign mineral carbonates, has been identified as a possible safe, long-term option for storing carbon dioxide by many authors(NETL, 2004), (Seifritz, W., 1990), (Lackner, K., Wendt, C. et al., 1995), (Morgantown, W. V.), (Dahlin, D. C., O'Connor, W. K. et al., 2000), (O'Connor, W. K., Dahlin, D. C., Nilsen, D. N., Walters, R. P., and Turner, P. C, 2000) (Fauth, D. J., Baltrus, J. P. et al., 2001).

Mineral sequestration is a process and number of universities and research organizations around the world are working on. Although there still some kinetic issues the process is workable.

TecEco have demonstrated that eco-cement concretes are suitable for block making and that they sequester considerable amounts of carbon dioxide.

The only component of the entire process that is not proven is the TecEco kiln technology. It will take about half a million Australian dollars to do so but this is small change for saving the planet.

The Economics of a Massive Sequestration Process

The cost of mineral sequestration even without the advantages added by TecEco technology is predicted to be quite reasonable.

Assuming thermodynamically efficient processes a cost including rock mining, crushing and milling, of around \$ US 20/tonne of CO₂ are suggested. For a 66% efficient power plant this would add less than 1 cent to the cost of a kilowatt hour of electricity (Yegulalp, T. M., Lackner, K. S. et al., 2001).

Should a price of carbon under the now legally binding Kyoto protocol be anything over \$ US 20/tonne of CO₂, the process would be economic once kinetic issues for chemically processing magnesium silicates are overcome.

A combined process involving TecEco tec-kiln technology would sequester several times more carbon and involve the eventual production of eco-cement concrete components that also sequester carbon to create the built environment and is therefore potentially very profitable even if an even lower price for carbon of say less than \$ 10.

The Kyoto protocol will also encourage the development of other technologies whereby CO₂ becomes a resource and as a result the process will eventually be supported by an economically driven price for CO₂. The use of TecEco eco-cements concretes would also be favoured as magnesite, the raw material, would not have to be mined. An added advantage would be the permanent disposal of carbon dioxide with no possibility for leakage.

Other Sustainable Binders

Tec-Cements

TecEco tec-cements include a much lower proportion of reactive magnesia and reduce emissions by further extending supplementary materials and reducing water whereby greater strength is obtained for less total binder. Further details are available from the TecEco web site.

Calcium Sulfoaluminate Cements

Calcium aluminate cements were developed in China during the 1970's at the China Building Materials Academy and were intended for the manufacture of

self – stressing concrete pipes due to their expansive properties. Sulfoaluminate cements contain as main phases belite (C₂S), tetracalcium trialuminate sulfate (C₄A₃S_{bar}) and gypsum. The main mineral formed is ettringite.

They have very low emissions associated with their manufacture and various blends with OPC and pozzolans are being trialed with some success.

Geopolymers

Geopolymers utilise silicon and aluminium containing raw materials like fly ash and metakaolin. As metakaolin has to be manufactured and therefore has an embodied energy, the objective, particularly for lower quality geopolymers, is to use as much fly ash as possible or fly ash only. Global supplies of ground granulated blast furnace slag are starting to run out and eventually fly ash will also become a scarce resource and cost more than it already does. It then becomes debatable whether the coal industry or geopolymer industry should bear the associated carbon tax.

Research into geopolymers is continuing and obstacles such as placement problems associated with extreme viscosity of the material and the critical quantitative addition of chemicals and water required are being investigated.

4. Sustainability is Good Business

In the past it was considered that economic development was linked to growth in the use of resources and energy and population growth. Most now understand that change is itself a stimulant for economic growth. We therefore have nothing to fear from the process of innovative change towards more sustainable outcomes.

Some businesses have pillaged resources and have not embraced sustainable development and the concept of natural capital (Hawken, P., Lovins, A. et al., 2000). Changing the way these businesses think is a matter of communicating to them that they can do something for themselves and the environment through greater resource use efficiency and reduced energy consumption. Sustainable development is about investing and strengthening socially and environmentally responsible businesses whilst at the same time reducing negative social or ecological consequences through awareness programs that slowly change the way in which more recalcitrant businesses operate.

To be acceptable in markets technology usually improves. For example fridges today are many times more efficient than fridges of twenty years ago – even without CFC refrigerants!

Not only are products rapidly becoming more efficient, so too are manufacturing processes. The biggest factor in increasing economic growth and raising living standards over time in the past has been the economy's ability to produce more out of less, i.e. to become more productive.

Productivity is good economics. Productive companies reduce inputs for the same output quality, volume and cost. They are much more efficient.

Mother nature was an economist. She is frugal, efficient, productive and integrated and by observing climax natural ecologies we can learn much about productivity and efficiency.

Increases in productivity not only bring greater profits, they reduce the demand on natural resources. Integrating productivity and efficiency across enterprises whereby communities get more out of less makes even more sense and can further reduce total take and waste impacts. The same applies on a global scale.

“Environmental protection is a market, not a cost” was the message of the keynote speaker, James B Quinn, at the recent forum on sustainable development at Parliament house Canberra, Australia (Quinn, P. J. B., 1999). Amory Lovins of the Rocky Mountain Institute puts it simply when he says that green technology “*will happen, and happen rapidly – because it’s profitable*” (Lovins, A., 2000).

Sustainability is good business. The main reason is simply a cost/value issue - recycling wastes and minimising inputs reduces input costs. In relation to construction, lower embodied and lifetime energies for buildings means that owning and living in them will cost less.

Applying Change – or Why Construction Materials in the Built Environment are so Important

When trying to solve a problem of immense proportions a good strategy is to first assess the solution, the means of applying it and the outcome from the effort of applying it. Put simply the input/outcome ratio or “bang for buck” is important for success. The obvious place that seems to have been missed by just about everybody to focus sustainability efforts is the built environment. It is our footprint on the globe. Given the size of the built environment there are huge opportunities for improving the techno-process and whilst doing so solving pollution and climate change problems.

The built environment is a major proportion of the techno-sphere and our lasting legacy on the planet. . In this dominant proportion of all materials flows unsustainable practices abound evidenced by the high volume of wastage going to landfill.

Most of what we take, manipulate and make that we do not consume immediately, goes into the materials with which we construct the built environment or “techno-sphere”. Buildings and infrastructure probably account for around 70% of all materials flows¹⁹. Of this “Buildings account for 40 percent of the materials and about a third of the energy consumed by the world economy. Combined with eco-city design principles, green building

¹⁹ TecEco estimate arrived at by including infrastructure with buildings.

technologies therefore have the potential to make an enormous contribution to a required 50% reduction in the energy and material intensity of consumption in the post-modern world (Rees, W. E., 1999).”

“In 1999, construction activities contributed over 35% of total global CO₂ emissions - more than any other industrial activity. Mitigating and reducing the impacts contributed by these activities is a significant challenge for urban planners, designers, architects and the construction industry, especially in the context of population and urban growth, and the associated requirement for houses, offices, shops, factories and roads (UNEP, 2001).”

Since the wealthiest 25 percent of the human population consume 80 percent of the world’s economic output (Bruntland, G. H., 1987), approximately 64 % of the world’s economic production/consumption and pollution is associated with cities in *rich* countries. Only 12 percent is tied to cities in the developing world (Rees, W. E., 1999). In short, “half the people and three-quarters of the world’s environmental problems reside in cities, and rich cities, mainly in the developed North, impose by far the greater load on the ecosphere and global commons(Rees, W. E., 1997)”.

Australia is one of the biggest energy consumers per capita in the world and has tripled consumption in the past 20 years with 94% of our current energy consumption from fossil fuels (2001).

According to the Human Settlements Theme Report, State of the Environment Australia 2001(CSIRO, 2001), “Carbon dioxide (CO₂) emissions are highly correlated with the energy consumed in manufacturing building materials. “On average, 0.098 tonnes of CO₂ are produced per gigajoule of embodied energy of materials used in construction. The energy embodied in the existing building stock in Australia is equivalent to approximately 10 years of the total energy consumption for the entire nation. Choices of materials and design principles have a significant impact on the energy required to construct a building. However, this energy content of materials has been little considered in design until recently, despite such impacts being recognized for over 20 years.”

To date urbanization has been considered as having serious negative implications for global sustainability. The impact of new materials such as TecEco eco-cement could reverse this as cities would become giant carbon sinks and repositories of what were formerly wastes. The impact of tec and eco-cements is discussed under the heading 3. Putting a Process Together on a Huge Scale to Save the Planet on page 56

Cities have dense concentrations of people, the juxtaposition of many industries and provide real opportunities to reduce energy and material through-put by integration beyond the enterprise level.

We use easily obtained fossil fuels to heat and power our complex civilisation, yet all the energy we will ever need is produced by our sun²⁰ and directly available as well as from natural forces of, wind, water and wave that are indirectly derived from the sun's energy reaching the earth. Sustainability embraces creating new from used, and requires minimal impact on natural resources such as old growth forest, coal or oil. Eventually it will mean living with the massive solar flux.

Table 2- Different Energy Fluxes on The Planet²¹

10¹³ Watts	Total	Heat	Wind	Evaporation	Photosynthesis
Solar	12100	8000	37	4000	4
Earth Heat	3.2				
Tidal	0.3				
World Techno-Process Energy Demand	1.5				

As can be seen from Table 2 fossil fuel energy is only a very small fraction of total energy on the planet.

To date the main practical emphasis has been on designing buildings with low lifetime energies. Little effort has been made to reduce the impact of materials on lifetime energies, embodied energies and emissions.

There is huge scope for sequestration and conversion of waste to resource given the massive size of the materials flows involved in the built environment. With the right materials technology, because of its sheer size, the built environment could reduce the take from the geosphere-biosphere and utilise many different wastes including carbon dioxide.

If sustainable development could be achieved then our cities could support large numbers of people while limiting their impact on the natural environment.

The Role of Various Players

As depicted in Figure 23 - A Total Life Cycle Approach to Materials on page 43 there are many players in the techno-process. There are also other influences because of the way these players operate.

Entrepreneurs and Innovation

Entrepreneurs (I consider myself to be one) are those rare optimistic individuals who conceive new business opportunities and who take on the risks required to convert those ideas into reality. They seek opportunities, both

²⁰ Every half-hour more solar energy strikes the Earth than is released globally by the burning of all fossil fuels in a year.

²¹ Estimated from various sources

for themselves and for the communities they belong to, and therefore are an important part of any society. As agents of change entrepreneurs take on the responsibility of identifying new commercial ventures, incubating ideas and championing their adoption, assembling the resources needed to bring these ideas to commercial reality and, finally, launching and growing business ventures.

In a market-based economy, environmental entrepreneurs will play a critical role in the adoption of green business practices. They constitute the main "pull" factor that entices architects and engineers to go green, as opposed to the "push" factors of government regulation and stakeholder/lobby group pressure.

All good teams need good leaders and much co-operative teamwork is required by the inhabitants of earth if we are to survive the long term future.

Consider why entrepreneurs do things. Perhaps it is because many of them have a mission in life other than just making money. According to Sean Covey, author of the 7 Habits of Highly Effective Teens, ' life is a mission, not a career. A career is a profession. A mission is a cause. A career asks, "What's in it for me?" A mission asks, "How can I make a difference?" Martin Luther King's mission was to ensure civil rights for all people. Gandhi's mission was to liberate 300 million Indians. Mother Teresa's mission was to clothe the naked and feed the hungry (Covey, S., 1999)." Many entrepreneurs have a passion to develop an idea or invention, run a better business - that is their mission; the money sometimes follows.

Governments around the world should do all in their power to encourage environmental entrepreneurs to take a greater and more rewarding role in markets as by doing so, new technologies will doubtless emerge resulting in less emissions and more efficient sequestration.

The Role of Government

The public has a perception that governments will do something about sustainability. They should be disappointed as in the past most effort has been mostly orientated towards mapping the extent of the problem, getting political mileage out of it and to some extent reducing energy consumption.

Unfortunately the democratic system has a fatal flaw. The outlook of politicians and thus governments is usually not much beyond the next election. As a consequence policy is generally extremely short sighted and too directly connected to the needs of the here and now rather than those of the future. Totalitarian governments can, in contrast move much more quickly such as demonstrated by the announcement by the Chinese central government of a move away from polluting clay bricks.

Global problems are not just the concern of one or two countries but all people on the planet. World federalists believe we need a system of democratic global governance on top of (not instead of) national governments.

Such a system would provide enforceable legal mechanisms for resolving conflicts and safeguarding the environment. Perhaps they have a point.

In spite of the two UN 'Habitat' conferences on urban prospects,²² cities have not been given serious attention in the mainstream sustainability debate. For example the World Conservation Strategy of 1980, which first used the term "sustainable development," paid little attention to accelerating urbanization. The Brundtland report (Brundtland, G. H., 1987) did discuss the issue, but the main emphasis was on the "urban crisis in developing countries.(UNCHS, 2004)"

"The population of cities is increasing much more than country areas and cities have a network of linkages that extend far beyond their boundaries. Sustainable urban development requires consideration of the carrying capacity of the entire ecosystem supporting such development, including the prevention and mitigation of adverse environmental impacts occurring outside urban areas. The unsafe disposal of waste leads to the degradation of the natural environment: aquifers, coastal zones, ocean resources, wetlands, natural habitats, forests and other fragile ecosystems are also affected (UNCHS, Current)".

It is essential that governments realise that urban settlement has much promise for human development and the protection of the world's natural resources. Dense concentrations of people and many industries, provides real opportunities to reduce energy and material through-put. Recycling based on the chemical composition of wastes is much more feasible in big cities not faced with transport issues for return to manufacturers. High population densities render economic rapid transport systems. Industrial wastes can be treated economically because of the economies of scale and the agglomeration economies of having many similar industries together.

Supporting moves towards greater sustainability in construction is a newly recognised direction for governments and will require further changes in the regulatory regime. Innovation is essential for change and change must occur, particularly with construction materials for greater sustainability.

In western countries the existing framework in which entrepreneurs can raise capital to bring to reality their creativity is market driven with little government assistance or intervention. For example at the present time in Australia S 708 of the Corporations Act 2001 is still far too restrictive as is the attitude of many of the venture capitalists – indeed the word "venture" has been misapplied. To change this market related inducements are required and arguably this is the role of government. To help create a new set of sustainable market segments it is encouraging that some governments are already introducing market drivers. In Australia the NSW government seems to be leading the way, and have introduced a framework for the recognition of carbon sequestration certificates. Hopefully the Australian Federal Government takes up the challenge and is not tardy in introducing a national system. Globally we have Kyoto and now it is a reality Australia and the US should join.

²² Vancouver in 1976 and Istanbul in 1996.

During the Clinton era the USA recognised the need to prime the pump with research. The present Bush regime is doing little.

The Australian Greenhouse Office have actively purchased abatement. Unfortunately however there has not been significant effort to incubate new sustainable technologies. Minor exceptions are some cleaner production initiatives under the Greenhouse Challenge Program.

The UK seem to be leading the field with Prime minister Tony Blair keen to develop three million new homes in the south west of Britain using more sustainable technology.

The point is that sustainable development can be achieved in cities and that they could support large numbers of people with limited impact on the natural environment. Governments generally need to realise this.

Sustainability should be a cornerstone for all government policy and expenditure. Governments should also facilitate economic systems that encourage sustainability such as performance standards, carbon trading and deposit legislation.

A change towards acceptance of products that are environmentally sustainable is occurring and will accelerate with the re-education activity of governments around the world. For sustainability the take and waste components of the techno-process need to be reduced and to what is renewable and preferably biodegradable.

Various policy options are being experimented with such as:

1. Research and Development Funding Priorities.

2. Procurement policies.

Government in most countries is more than 1/3 of the economy and can strongly influence change through:

- Life cycle purchasing policy.
- Funding of public projects and housing linked to sustainability such as **recycling**.

3. Intervention Policies.

- Building codes including mandatory adoption of performance specification.
- Requiring the recognition and **accounting for externalities**
- **Extended producer responsibility (EPR) legislation**
- Mandatory use of minimum standard materials that are more sustainable
- Mandatory eco-labelling

3. Taxation and Incentive Policies

- Direct or indirect taxes, bonuses or rebates to discourage/encourage sustainable construction etc.
- A national system of carbon taxes.
- An international system of carbon trading.

5. Sustainability Education

Consider building codes, research and development funding and policies of encouraging recycling and legislating for extended user responsibility as they are most relevant to the materials theme of this chapter.

Building Codes

The emphasis has been on lifetime rather than embodied energies because potential lifetime energy reductions through good design are significant. Most OECD countries have set up energy efficiency standards for new dwellings and service sector buildings: this includes all European countries, Australia, Canada, the USA, Japan, Korea and New Zealand. Some non-OECD countries outside Europe have also established mandatory or voluntary standards for service buildings and Singapore and the Philippines were among the first.

To date building codes have not encouraged the use of more energy efficient materials, in spite of the huge impact of materials not only on embodied energies but lifetime energies as well.

Research and Development Funding Priorities

The early North American and to some extent European approach was to “prime the pump” and research global warming. The early Australian approach to sustainability was much cruder and involved the outright purchase of abatement with little research. To date materials science, which this paper demonstrates is fundamental, has received little funding globally.

As of early 2004 European priorities were genomics and biotechnology for health, information society technologies, nanotechnologies, intelligent materials and new production processes, aeronautics and space, food safety and health risks, sustainable development and global change, citizens and governance in the European knowledge-based society. In the USA Federal funding priorities include nanotechnology, defense, and aeronautics.

Geological sequestration has also been a priority in many countries as it is associated with the petroleum industry and doubts have been raised as to the transparency of funding (Wilson, N., 2004).

To date Australian research priorities have not included materials science however the Australian research funding priorities for 2004 – 2005 may well lead the way globally as included under the heading “Frontier Technologies for Building and Transforming Australia” are advanced materials. “Advanced materials for applications in construction, communications, transport, agriculture and medicine (examples include ceramics, organics, biomaterials, smart material and fabrics, composites, polymers and light metals) (ARC, 2004)”.

Recycling

Recycling involves a series of activities by which wastes are collected, sorted, processed and converted into raw materials and used in the production of new products.

Recycling is carried out by individuals, volunteers, businesses and governments. For high value waste recycling is profitable and undertaken by business, usually by buying back wastes, but not so as the value declines. Governments generally have recognized the importance of recycling but have gone about the introduction of recycling through councils and local authorities in completely the wrong way. As the hazards of discarded wastes do not correlate with their value, many wastes are recycled by the authority of legislation or power of producer organisations.

Instead of being forced upon us using good taxpayer dollars for “feel good” reasons, much more effort should have been put into the development of technologies to make the process economic. With market forces driving recycling much more would occur much more efficiently.

The problem is to make the process of recycling less “feel good” and more economic so it is driven by market forces. The solution is to use materials not just for their chemical composition but for their physical property. TecEco cements open this possibility.

Accounting for Externalities - the True Cost of the Techno-process

“...the exponential growth curve of cost associated with negative impacts or "externalities" such as climate change, salinity, acid sulphate soils, river system degradation, or general pollution, has up until now, been a legacy for future generations to deal with. For decades the cash price of goods and services has been artificially deflated, with much of the real cost being outsourced on to the environment.

The costs, however, that are backing up on us - bush fires, dust storms, floods, soil erosion, salinity, changes in disease patterns, hurricanes and cyclones - can often be attributed, at least in part, to climate change. An integral part of the dilemma we have is the denial that anything truly threatening is happening (Wain, F., 2004).”

Accounting standards that recognise the value of natural capital (Hawken, P., Lovins, A. et al., 2000) are required so that the true costs of techno-processes that extract and waste are born by those who gain the benefit of doing so.

Extended producer responsibility (EPR)

EPR incorporates negative externalities from product use and end-of-life in product prices. Producers are made responsible for environmental effects over the entire product life cycle so that the cost of compliance cannot be shifted to a third party and must therefore be incorporated into product prices.

Examples of EPR regulations include emissions and fuel economy standards (use stage) and product take back requirements (end of life) such as deposit legislation, and mandatory returns policies which tend to force design with disassembly in mind.

Producers are made responsible for collecting and recycling end-of-life products. Waste-management costs are shifted to those most capable of reducing disposal costs by changing designs for recyclability, longevity, reduced toxicity, and limited volume of waste generated. Disposal costs are reflected in product prices so consumers can make more informed decisions.

The above solutions all involve a cost. What if benefits could be incorporated?

What Governments Should be Doing and Why

Governments appear not to understand or see the benefit of fostering change to the techno process whereby they could substantially alleviate the problems of the planet. If some do, the evidence that they have done little about it is the low priority for materials research.

According to Paul Zane Pilzer “technology is the major determinant of wealth as it determines the nature and supply of physical resources (Pilzer, P. Z., 1990).” Why then is it that so little government research funding is to change the technical paradigm for reducing, re-using and recycling materials? Materials are after all a major part of the flow of resources in the techno-process and fundamental for sustainability. Governments need to focus on fundamental research that leads to change in the technology factor. As Pilzer’s first law states “By enabling us to make productive use of particular raw materials, technology determines what constitutes a physical resource (Pilzer, P. Z., 1990).” Pilzer goes on further to explain that definitional technologies are those that enable us to make use of particular resources. Wastes are potentially a huge resource. Improvements in recovery and utilisation technologies will one day make them of significant value.

Fortunately some governments such as the EU are starting to research how we could live more sustainably on the planet. I am not however aware of any country or group of countries that prioritise the development research into materials as a way of reducing the take and waste in the techno-process, maximising utility and making re-use and recycling more profitable.

It is important that governments all over the world co-operate to bring about sustainability, take an active role and recognize their responsibility to seek sustainability as a cornerstone to all government expenditure and policy. They must facilitate economic systems that encourage sustainability such as carbon trading and EPR. The challenge is to achieve “common good” without a disproportionate impact on taxation.

Professionals

There are a large number of professionals, professions and industries involved in the value chain through the techno-process. The approach must

not only be holistic in terms of what is done but holistic in that it involves a wide range of people.

With particular reference to the construction business, the challenge is to:

- understand materials
- Implement them in more sustainable ways.

Architects (Including specifiers)

Architects and their specifiers dictate what sort of space we live in, with what material and how that space is constructed. They have been responsible for much of the reduction in lifetime energies of buildings so far achieved.

Architects:

- prescribe the sorts of spaces and the configurations of those spaces which directly affect how we interact with others inside and outside them.
- decide what materials the spaces are built with and how they affect our health and the health of the environment.
- decide how the spaces relate one to another and to the outside world. They determine if the spaces are separate entities or connected, whether they look inward or outward, whether they encourage interaction or isolation.
- prescribe how we furnish our spaces. Indeed architects are the arbiters of taste in buildings rather like fashion houses direct what we wear.

Many new materials offer interesting architectural features taking them beyond mere product. The ability to design materials as products will change the relationship between scientists, architects and engineers. “The architect becomes a coordinator between various kinds of embedded intelligences, applying their knowledge to create something society needs, instead of the usual passive role of an architect selecting given products (Griff, A., 2004)”

Engineers

Engineers hang the dreams of architects together as structural reality in 3D space. They turn complex ideas into reality and are therefore involved in some of the most innovative and sustainable new structures in the world.

Town Planners

Town planners build cities. They decide where to place suburbs and how suburbs will look in relation to houses, transport, facilities, activities etc. Town planners oversee the development of an entire town or region and must

understand the needs of the environment, local environment, economy and population and how to interact those needs.

In this role, and as the people who approve building construction, town planners are pivotal if we are to have more sustainable communities.

Conclusion

Materials are the key to sustainability in the built environment and innovative new materials will allow architects and engineers to build structures that have greater value as they are more pleasing to use, live in or look at, healthier for us and much more sustainable.

Huge quantities of materials are used. Their choice profoundly affects many value properties relevant to sustainability including weight, embodied energies, fuel related and chemical emissions, lifetime energies, user comfort and health, use of recycled wastes, durability, recyclability and the properties of wastes returned to the geosphere-biosphere.

A holistic approach to sustainability in which all things possible are done is most likely to work and the built environment offers tremendous opportunities for the cultural and technical changes required.

Exciting new benchmark technologies such as tec and eco-cements offer a way forward and of solving the two greatest problems on the planet of global warming and waste.

The direction is clear, technology can help us change the techno process. By doing so the process becomes more economic and thus self propelled with less government intervention.

Finding 3 under the heading Transport and Urban Design of the recent ISOS conference in Australia applies globally. It stated in part. "...The Federal Government should promote Australian building innovations (e.g. eco-cement) that contribute global solutions towards sustainability; provide more sustainable city innovation R&D funds; and re-direct some housing and transport funds towards sustainable cities demonstration projects²³."

Technology can make it possible to achieve a far greater measure of sustainability, to economically reduce, re-use and recycle. The potential multipliers from spending on research and development are huge.

As Fred Pearce reported in New Scientist Magazine (Pearce, F., 2002), "There is a way to make our city streets as green as the Amazon rainforest".

²³ ISOS Conference, 14th November Canberra, ACT, Australia communique downloadable from <http://www.isosconference.org.au/entry.html>.

Appendix 1.

Suggested Policies for Governments for a Sustainable Built Environment.

Many countries in the world such as Canada, the UK and the US have targeted research as means of priming the pump to address sustainability, climate action and other environmental ramifications of urban development. In spite of much rhetoric, the reverse has been the case in Australia. Research funding is driven by market forces and abatement for example blatantly market driven with the Australian Greenhouse Office doing little more than buying emissions reductions.

A genuine national carbon trading system would be better than the fragmented one that is currently evolving and the Federal government should as a priority introduce such a system to add confidence to the carbon dollar. Now that Kyoto is a reality joining would seem appropriate.

It makes sense economically to reduce emissions (given scale, emissions = energy = money (and with carbon trading, more money)). Market forces alone will not however be enough to drive important research into materials, argued in this chapter as fundamental to sustainability. , More subtle government intervention and funding is required.

In January 2002, four priority areas were identified in Australia for ARC funding: Complex / Intelligent Systems, Genome / Phenome Research, Nano- and Bio- materials and Photon Science and Technology. As of January 2004, the funding agencies have still not caught up with the importance of funding materials science as the key to the changes in our usage patterns required for sustainability.

The mechanisms available to the Commonwealth Government to bring about change towards sustainability, particularly in the built environment where ecologically sustainable patterns of settlement are required include:

1. Research and Development Funding Priorities to included the funding of research development and deployment of new materials technologies.
2. Procurement policies:
Government in Australia is more than 1/3 of the economy and can strongly influence change through:
 - Life cycle purchasing policy.
 - Funding of public projects and housing linked to sustainability
3. Intervention Policies
 - Building codes including mandatory adoption of performance specification.

- Deposit legislation on not just packaging, but a wide range of goods including pallets and other commonly thrown away recyclables in construction
- Encouragement of Cradle to Cradle Loops
- Mandatory use of minimum standard materials that are more sustainable

4. Taxation and Incentive Policies

- Direct or indirect taxes, bonuses, grants or rebates to discourage/encourage sustainable construction etc.
- A national system of carbon taxes.
- An international system of carbon trading.

5. Sustainability Education

In the context of the built environment:

1. Research and Development Funding Priorities to included the funding of research development and deployment of new materials technologies.

National priorities for research need to be brought up to date with the urgent requirements for climate action and should include materials science, energy and sustainable technologies. Such changes should urgently reflect in ARC funding policy.

To “prime the pump” and get urgent research development and deployment happening direct funding as a matter of national importance of promising new materials science breakthroughs should be considered. TecEco as one of the lead companies in the race for more sustainable materials and would be prepared to negotiate a share in royalty income with the government in.

2. Procurement policies:

Life cycle purchasing policy.

The development of purchasing procedures that are governed by life cycle performances will be a strong tool for the government to assess and adopt materials that will have an overall minimal impact on the environment, society and economics of the nation.

Funding of public projects and housing linked to sustainability

Prescriptive specifications detail the material to be used for a project. If the Commonwealth Government specified the use of new more sustainable materials such as TecEco’s magnesium-based cements in appropriate construction projects (following verification research), it would know that certain measures to bring about urban development reform were being met.

In order to bring this about is will be necessary to employ sustainable champions. Akin to a quantity surveyor, such champions would have the role

of keeping the project on track to ensure that material selection and procedures have minimal detrimental impacts.

3. Intervention Policies

Building codes including mandatory adoption of performance specification.

Current outdated formula based standards supported by the industry because of vested interests and fear of change should be required to follow the modern trend of performance based specifications giving suppliers criteria to adhere to. As a matter of urgency the Commonwealth Government could adopt performance-based specifications for cement /concrete that:

- restrict the amount of embodied energy,
- restrict the associated emissions of greenhouse gases and
- detail the durability and other characteristics of the finished product.

Formula based standards are holding up the development of much better composite materials directed towards existing market demand for more than just strength. Other desirable properties such as durability, insulating capacity, light weight and so on can only be introduced by innovation currently throttled by formula based standards. Given the volume of materials flows the sustainability outcomes of a shift to performance based standards will be significant.

National Deposit Legislation.

The wastage of brand new materials on a building site is appalling and in Australia around 15%. The quantity of used materials from building and construction going to landfill in Australia is around 40%(Atkinson, M., 2003) and higher in Europe with greater building churn.

In the context of construction deposit legislation covering items commonly thrown away that could be recycled may be in order. A novel idea and world first would be to include bricks, blocks, glass, metal roofing iron and many other recyclable building products. Savings in landfill costs alone would make the proposal worthwhile.

Facilities are already available in most cities to accept such waste. The new TecEco cements will help get over some problems such as gypsum in recycled building aggregates and sodium leaching out of glass cullet.

Encouragement of Cradle to Cradle Loops (McDonough, W. and Braungart, M., 2002)

To encourage recycling and remanufacturing the concept of service should be encouraged. For example if heating and lighting were supplied instead of electricity, utilities would make sure the most efficient systems available were installed. Returning the responsibility for products including their disposal or reuse back to manufacturers has merit in that recycling is encouraged and

quality assured. Technical recycling is kept within the technosphere and biological recycling less likely to be tainted.

Mandatory use of Minimum Standard Materials that are more Sustainable

As the need is urgent it may be necessary to ensure the changes required come about to develop legislation requiring the mandatory use of more sustainable materials such as the calcium magnesium cement blends proposed by TecEco.

4. Taxation and Incentive Policies

Direct or indirect taxes, grants, bonuses or rebates to discourage/encourage sustainable construction etc.

Taxes and rebates are a powerful tool in the hands of governments to direct expenditure in perceived desirable directions.

A National System of Carbon Taxes

The proliferation of various state run systems such as in Queensland and NSW should be superseded as soon as possible by worthwhile national carbon trading legislation secured by agreement with the states and ideally as part of the Kyoto protocol.

Such a step may be difficult to implement, but should not cost the public purse much. A significant outcome would be the leverage to market forces already in present that will bring about quantum improvements in sustainability at little overall net cost, but much required reallocation of capital.

An International System of Carbon Trading

Joining Kyoto would internationalize and legitimize carbon trading and would be worth if for the carbon credits attached to multiple cycle TecEco sequestration technology if for no other reason.

5. Sustainability Education

Emphasis needs to be given to education across all disciplines in relation to sustainability. The sustainability of the built environment is influenced by a wide range of professionals including investors, developers, local governments, clients, accountants and many more. An understanding of sustainability needs to be fostered from a young age in everyone.

It should be mandatory for engineers to include more materials science in their courses as many have little understanding of the environmental impact of the materials they use. The education of professionals into the consequences of using different materials and the benefits of using sustainable materials is a high priority and should be linked to higher education funding.

Conclusion

The role of governments is to ensure that public need is addressed even if the public do not understand that need. Action is required to address climate change and the more subtle detrimental affects of sprawling urban settlement. Policies and actions are required that do not impinge too heavily on budgets and several such legislative and policy opportunities to bring about the changes required have been suggested in this section.

If all Australian governments committed to building social, environmental and economic sustainability into every element of governance, we could be an example to the rest of the world.

The manufacture and use of low energy, low emissions cements has been demonstrated by TecEco to be technically feasible and should be encouraged as a matter of national importance utilising policies such as those suggested.

References

- (2001). The Sunday Tasmanian. Hobart,
- (2004). The Mercury. Hobart, 3.
- AAAS (2004). American Association for the Advancement of Science Population and Environment Atlas, Secondary American Association for the Advancement of Science Population and Environment Atlas. Secondary AAAS, Place Published, AAAS American Association for the Advancement of Science, <http://atlas.aaas.org/index.php?part=1&sec=waste>,
- Annual Amount and Composition of Waste Consigned to Landfill (2004). Secondary Annual Amount and Composition of Waste Consigned to Landfill. Secondary, Place Published, Department of Environment and Heritage, South Australia, <http://www.environment.sa.gov.au/reporting/human/waste/landfill.html>,
- ARC (2004). National Research Priorities and Associated Priority Goals, Secondary National Research Priorities and Associated Priority Goals. Secondary ARC, Place Published, http://www.arc.gov.au/pdf/2004_designated_national_research_priorities_and_associate.pdf,
- Atkinson, M. (2003). Keynote Address, Energy Efficiency Conference.
- Batterham, R. (2004). Point Carbon,
- Benyus, J. M. (1997). Biomimicry, Innovation Inspired by Nature, HarperCollins Books.
- Brown, P. (2004). Melting ice: the threat to London's future, The Guardian,
- Bruntland, G. H., Ed. (1987), Our Common Future, Report of the World Commission on Environment and Development (WCED), Oxford University Press.
- c-f-c.com (2004). Chlorofluorocarbons - CFC's, Secondary Chlorofluorocarbons - CFC's. Secondary c-f-c.com, Place Published, <http://www.c-f-c.com/supportdocs/cfcs.htm>,
- Campbell, C. (2002). How Long Can Oil the Last.
- Campbell, C. (2004). Oil and Gas Liquids, 2004 Depletion Scenario., Secondary Oil and Gas Liquids, 2004 Depletion Scenario. Secondary Campbell, C., Place Published, Association for the Study of Peak Oil, <http://www.peakoil.net/uhdsg/Default.htm>,
- CICA (2002). "Industry as a partner for sustainable development."
- CMDL (2003). Carbon Cycle-Greenhouse Gases, National Oceanic and Atmospheric Administration (NOAA), Climate Monitoring and Diagnostics Laboratory (CMDL),
- Commoner, B. (1972). "The Environmental Costs of Economic Growth." Chemistry in Britain 8(2): 52-65.
- Covey, S. (1999). The 7 Habits of Highly Effective Teens, Glasgow, Simon & Schuster.
- CSIRO (2001). Human Settlements Theme Report, State of the Environment Australia 2001, Australian Government Department of Environment and Heritage,

- Dahlin, D. C., O'Connor, W. K., et al. (2000). A method for permanent CO2 sequestration: Supercritical CO2 mineral carbonation, 17th Annual International Pittsburgh Coal Conference.
- Doyle, A. (2004). Reuters, U K,
- Durie, R. A. (1998). Invited keynote address: Australian Greenhouse Gas Mitigation Responses, Sustainable Energy and Environmental Technology. Gold Coast, Australia,
- Electronic Universe Educational Server (2004). Secondary Electronic Universe Educational Server. Secondary, Place Published, University of Oregon, <http://zebu.uoregon.edu/1998/es202/l14.html>,
- EPA (2003). "Office of Solid Waste Strategic Planning Document 2003 - 2008."
- Fauth, D. J., Baltrus, J. P., et al. (2001). "Carbon Storage and Sequestration as Mineral Carbonates." Prepr. Symp. Am. Chem. Soc., Div. Fuel Chem **46(1)**: 278.
- Gelbspan, R. (2004). "Toward A global Energy Transition."
- Gismondi, M. and Rees, W. E. (2004). Aurora on Line with William Rees, Secondary Aurora on Line with William Rees. Secondary Gismondi, M. and Rees, W. E., Place Published, <http://aurora.icaap.org/talks/rees.html>,
- GISS (2002). "Global Trends: 2002 Summation."
- GISS (2005). Global Temperature Anomaly, Secondary Global Temperature Anomaly. Secondary GISS, Place Published, NASA GISS, <http://www.giss.nasa.gov/data/update/gistemp/graphs/Fig.A.pdf>,
- Griff, A. (2004). Material Matters, LA Architect. Los Angeles, L A Architect, 30-35.
- GRRN (2000). "Wasting and Recycling in the United States 2000."
- Harrison, P. (1992). "The Third Revolution, Environment, Population and a Sustainable World."
- Haughton, R. (2004). Understanding the Global Carbon Cycle, Woods Hole Institute,
- Hawken, P., Lovins, A., et al. (2000). "Natural Capitalism: Creating the Next Industrial Revolution."
- Hendriks, C. A., Worrell, E., et al. (2002). Emission Reduction of Greenhouse Gases from the Cement Industry, International Energy Agency (IEA),
- Herbertson, J. (2004). Strategic Drivers and Emerging Directions: Creating the material foundations for a built environment in Australia that is truly sustainable. Coming from the sustainable material supply direction, Innovation||Sustainability||Materials, Melbourne, AASMIC and the Centre for Design.
- Herbertson, J. and Green, M. (2003). Research data, The Natural Step,
- Herbertson, J. and Sutton, P. (2002). "Foundations of Sustainable Resource Processing." Green Processing 2002.
- Hillman, M. and Fawcett, T. (2004). How We Can Save the Planet, London, Penguin Books.
- IEA (2003). Key World Energy Statistics, Secondary Key World Energy Statistics. Secondary IEA, Place Published, <http://www.iea.org/bookshop/add.aspx?id=144>,
- Johannes, R., Earle (1992). "Words of the Lagoon: Fishing and Marine Lore in the Palau Distric, Micronesia."

- Kimball, J. W. (2004). Kimball's Biology Pages, Secondary Kimball's Biology Pages. Secondary Kimball, J. W., Place Published, John W Kimball, <http://users.rcn.com/jkimball.ma.ultranet/BiologyPages/C/CarbonCycle.html>,
- Lackner, K., Wendt, C., et al. (1995). "Energy." **20**: 1153 - 1170.
- Langenfields, R. (2003). Oxygen measurements yield greenhouse clues, Secondary Oxygen measurements yield greenhouse clues. Secondary Langenfields, R., Place Published, CSIRO, <http://www.csiro.au/index.asp?id=OxygenMeasurements&type=mediaRelease>,
- Lovins, A. (2000). The Bulletin,
- Malthus, T. (1798). An Essay on the Principle of Population, as it Affects the Future Improvement of Society with Remarks on the Speculations of Mr. Godwin, M. Condorcet, and Other Writers, J. Johnston, Opp. St. Paul's Church-yard.
- Marland, G., Boden, T. A., et al. (2003). Global, Regional, and National CO2 Emissions, Trends: A Compendium of Data on Global Change, Carbon Dioxide Information Analysis Center, Oak Ridge National Laboratory, U.S. Department of Energy, Oak Ridge, Tenn., U.S.A.
- Matear, R. (2002). Deep Ocean Losing Oxygen, Secondary Deep Ocean Losing Oxygen. Secondary Matear, R., Place Published, CSIRO, <http://www.csiro.au/index.asp?id=proceanoxygen&type=mediaRelease>,
- McDonough, W. and Braungart, M. (2002). Cradle to Cradle: Remaking the Way We Make Things, North Point Press.
- MIRO (2002). RC114 - Targeted Research Action on Waste Minimisation and Recycling, Secondary RC114 - Targeted Research Action on Waste Minimisation and Recycling. Secondary MIRO, Place Published, Mining Industry Research Organisation (MIRO), <http://www.miro.co.uk/projects/arcprojs/rc114.htm>,
- Morgantown, W. V., Secondary. Secondary Morgantown, W. V., Place Published, <http://www.fetc.doe.gov/products/ggc>,
- NETL (2004). Chemical and Geologic Sequestration of Carbon Dioxide, Secondary Chemical and Geologic Sequestration of Carbon Dioxide. Secondary NETL, Place Published, National Energy Technology Laboratory (NETL), http://www.netl.doe.gov/products/r&d/annual_reports/2001/cgscdfy01.pdf,
- O'Connor, W. K., Dahlin, D. C., Nilsen, D. N., Walters, R. P., and Turner, P. C (2000). "Carbon Dioxide Sequestration by Direct Mineral Carbonation: Results from Recent Studies and Current Status." Proceedings of the 25th International Technical Conference on Coal Utilization & Fuel Systems: 153 - 164.
- Pearce, F. (1997). "The Concrete Jungle Overheats." New Scientist(2097): 14.
- Pearce, F. (2002). "Green Foundations." New Scientist **175**(2351): 39-40.
- Pilzer, P. Z. (1990). Unlimited Wealth - The Theory and Practice of Economic Alchemy, Crown Publishers.
- Quinn, P. J. B. (1999). Keynote address, Forum on Sustainable Development, Forum on Sustainable Development, Parliament House, Canberra.

- Rees, W. E. (1997). "Is "Sustainable City" and oxymoron?" Local Environment **2**: 303-310.
- Rees, W. E. (1999). "The Built Environment and Ecosphere: A Global Perspective." Building Research and Information **27**(4/5): 206-220.
- Sanjour, W. (2001). "Royal Roads University Waste Audit Report."
- Schaller, D. (2004). Beyond Sustainability: From Scarcity to Abundance, BioInspire Newsletter. Denver,
- Seifritz, W. (1990). Nature **345**, **486**.
- Seligman, M. E. P. (1990). Learned Optimism, Learned Optimism: How to Change Your Mind and Your Life, New York, Pocket Books - Simon & Schuster, Inc.
- Sharp, L. (2003). "Green Campuses, The Road from Little Victories to Systemic Transformation."
- Steffen, W. and Tyson, P. (2001). Global Change and the Earth System: A planet under pressure., Secondary Global Change and the Earth System: A planet under pressure. Secondary Steffen, W. and Tyson, P., Place Published, International Geosphere-Biosphere Programme (IGBP), <http://www.igbp.kva.se/cgi-bin/php/frameset.php>,
- Sutton, P. (2002). Greenleaps newsletter, Secondary Greenleaps newsletter. Secondary Sutton, P., Place Published,
- Tucker, S. (2000). CSIRO on line brochure, Secondary CSIRO on line brochure. Secondary Tucker, S., Place Published, <http://www.dbce.csiro.au/ind-serv/brochures/embodied/embodied.htm>,
- Tucker, S. (2002). CSIRO Department of Building Construction and Engineering. J. Harrison, pers. comm.
- Twain, M.
- UN (2002). "World Population Prospects: The 2002 Revision Population Database."
- UNCHS (2004). Global Trends, Secondary Global Trends. Secondary UNCHS, Place Published, United Nations Human Settlements Programme, <http://www.unchs.org/habrdd/global.html>,
- UNCHS (2004). The Habitat Agenda, Secondary The Habitat Agenda. Secondary UNCHS, Place Published, United Nations Human Settlements Programme,
- UNCHS (Current). The Habitat Agenda, Secondary The Habitat Agenda. Secondary UNCHS, Place Published, United Nations Human Settlements Programme,
- UNEP (2001). Energy and Cities: Sustainable Building and Construction Summary of Main Issues, IETC Side Event at UNEP Governing Council, Nairobi, Kenya, UNEP.
- UNESCO (2004). New Role of Education, Secondary New Role of Education. Secondary UNESCO, Place Published, United Nations Educational, Scientific and Cultural Organisation,
- USGS (2000). "Mineral Commodity Summary - Cement." (2004).
- USGS (2004). "Mineral Commodity Summary - Cement." (2004).
- Van Oss, H. (2004). "Mineral Commodity Summary - Cement." (2004).
- Van Oss, H., G., Hendriks, K., et al. (2003). USGS cement XLS file. Data,
- Vitousek, P. M., Mooney, H. A., et al. (1997). "Human Domination of Earths Eco-Systems." Science **277**(July): 494-99.

- Von Weizsäcker, E. U., Lovins, A. B., et al. (1997). Factor four: Doubling Wealth, Halving Resource Use, London, Earthscan.
- Wain, F. (2004). The Canberra Times. Canberra,
- Wain, F. (2004). "The real cost and implications of collateral damage." The Canberra Times.
- Wilson, A. (1993). "Cement and Concrete: Environmental Considerations." Environmental Building News 2(2).
- Wilson, N. (2004). "Call for public input to carbon plan." The Weekend Australian(May 1-2, 2004): Resources, 7.
- WRI (1998). WRI, 1998-99 Database Diskette, Secondary WRI, 1998-99 Database Diskette. Secondary WRI, Place Published, World Resources Institute, <http://www.wri.org/>,
- WRI (2004). World Resources 2002-2004, Secondary World Resources 2002-2004. Secondary WRI, Place Published, World Resources Institute, <http://www.wri.org/>,
- WWF (2004). WWF's Living Planet Report, Secondary WWF's Living Planet Report. Secondary WWF, Place Published, World Wildlife Fund, http://www.panda.org/news_facts/publications/general/livingplanet/index.cfm,
- Yegulalp, T. M., Lackner, K. S., et al. (2001). "A Review of Emerging Technologies for Sustainable Use of Coal for Power Generation." The International Journal of Surface Mining, Reclamation and Environment 15(52 - 68): 58.